

# CERN COURIER

VOLUME 39 NUMBER 3 APRIL 1999

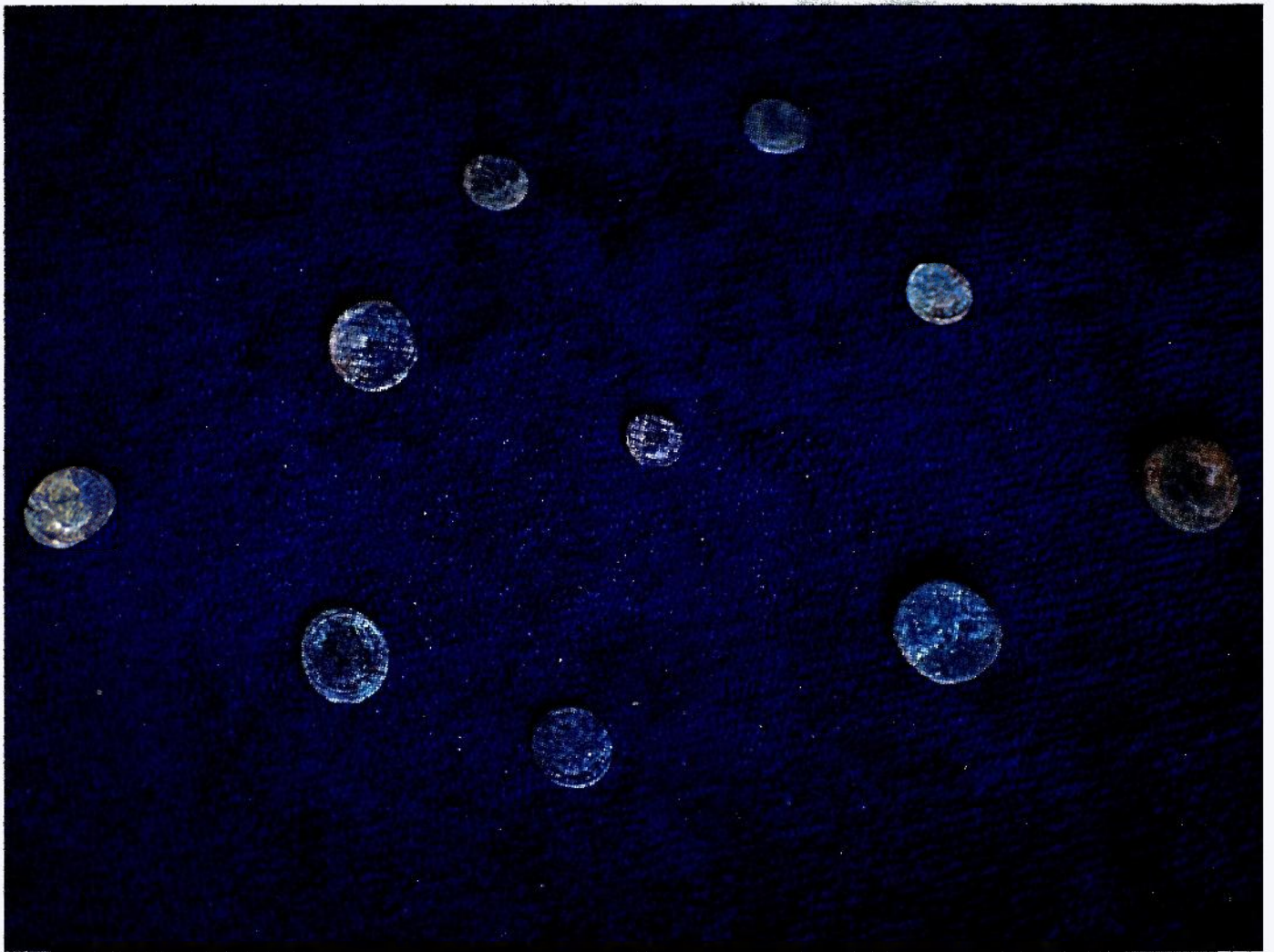

## Roman coins and Roman pots

### THE RETURN OF ANTIMATTER

A new machine for an antiproton renaissance at CERN

### SILICON DETECTORS

Robust new solutions push up daisies or come up roses

### QUANTUM GRAVITY

Superstrings, black holes and gauge theories make a heady mix

# The Power You Need<sup>SM</sup>

## PowerMod<sup>TM</sup> Switching Power Supplies From DTI - The Experts in High Power Solid-State Technology

DTI is the Complete Source for Solid State High Voltage Systems

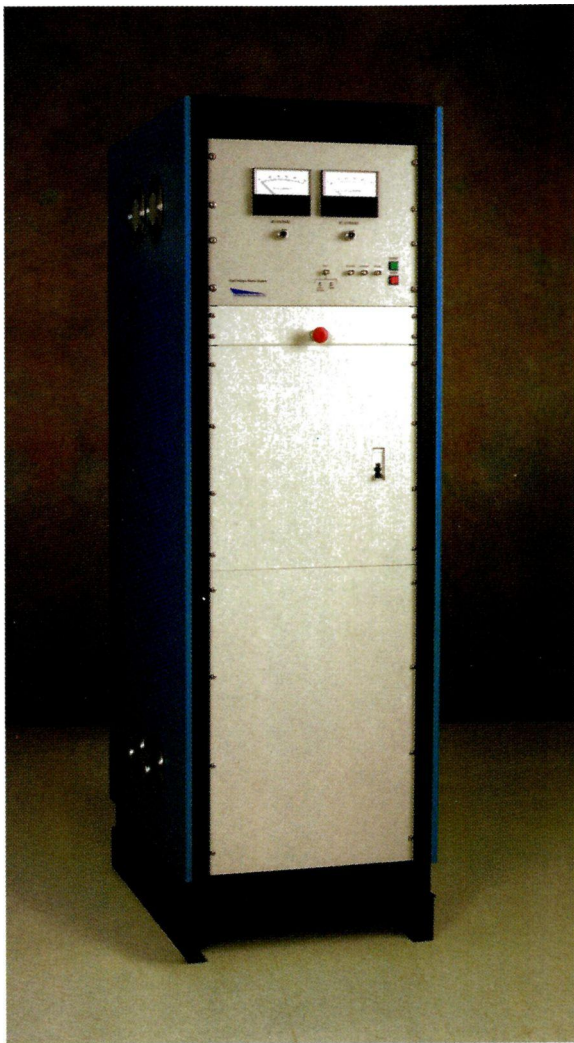

PowerMod<sup>TM</sup>HVPS-100 100 kV, 100 kW,  
Free Standing DC Power Supply

### Switching Power Supplies

- 10 - 200 kV
- 10 - 200 kW Average Power
- Custom Power Supplies to 10 MW
- High Reliability
- High Power Without Stacking Multiple Units



PowerMod<sup>TM</sup> HVPS-30 20 kV, 30 kW Rack  
Mount DC Power Supply

DTI's award-winning, solid-state, high-power systems provide reliable power to leading commercial, research, and government organizations world-wide. Call DTI or visit our web site today for more information.

**DIVERSIFIED TECHNOLOGIES, INC**

35 Wiggins Avenue Bedford, MA 01730 781-275-9444

[www.divtecs.com](http://www.divtecs.com)

Covering current developments in high-energy physics and related fields worldwide

CERN Courier is distributed to Member State governments, institutes and laboratories affiliated with CERN, and to their personnel. It is published monthly except January and August, in English and French editions. The views expressed are not necessarily those of the CERN management.

**Editor:** Gordon Fraser  
 CERN, 1211 Geneva 23, Switzerland  
 E-mail cern.courier@cern.ch  
 Fax +41 (22) 782 1906  
 Web http://www.cerncourier.com

**Advisory Board**  
 R Landua (Chairman), F Close, E Lillestøl, H Hoffmann, C Johnson, K Potter, P Sphicas

**Laboratory correspondents**  
**Argonne National Laboratory (USA):** D Ayres  
**Brookhaven, National Laboratory (USA):** P Yamin  
**Cornell University (USA):** D G Cassel  
**DESY Laboratory (Germany):** Ilka Flegel, P Waloschek  
**Fermi National Accelerator Laboratory (USA):** Judy Jackson  
**GSI Darmstadt (Germany):** G Siegert  
**INFN (Italy):** A Pascolini  
**IHEP, Beijing (China):** Qi Nading  
**Jefferson Laboratory (USA):** S Corneliussen  
**JINR Dubna (Russia):** B Starchenko  
**KEK National Laboratory (Japan):** A Maki  
**Lawrence Berkeley Laboratory (USA):** B Feinberg  
**Los Alamos National Laboratory (USA):** C Hoffmann  
**NIKHEF Laboratory (Netherlands):** Margriet van der Heijden  
**Novosibirsk Institute (Russia):** S Eidelman  
**Orsay Laboratory (France):** Anne-Marie Lutz  
**PSI Laboratory (Switzerland):** P-R Kettle  
**Rutherford Appleton Laboratory (UK):** Jacky Hutchinson  
**Saclay Laboratory (France):** Elisabeth Locci  
**IHEP, Serpukhov (Russia):** Yu Ryabov  
**Stanford Linear Accelerator Center (USA):** M Riordan  
**TRIUMF Laboratory (Canada):** M K Craddock



Produced for CERN by Institute of Physics Publishing Ltd  
 IOP Publishing Ltd, Dirac House, Temple Back, Bristol BS1 6BE, UK  
 Tel. +44 (0)117 929 7481  
 E-mail mark.wormald@ioppublishing.co.uk  
 Web http://www.iop.org

**Publishing director:** Mark Ware  
**Publisher:** Mark Wormald  
**Art director:** Andrew Giaquinto  
**Production editor:** Kate Boothby  
**Technical illustrator:** Alison Tovey  
**Sales manager:** Harvey Stockbridge  
**Advertising sales:** Jo Nicholas  
**Classified sales:** Chris Thomas  
**Advertisement production:** Katie Graham

**Advertising:** Jo Nicholas or Chris Thomas  
 Tel. +44 (0)117 930 1026  
 E-mail sales@cerncourier.com  
 Fax +44 (0)117 930 1178

**General distribution**  
 Jacques Dallemagne, CERN, 1211 Geneva 23, Switzerland.  
 In certain countries, to request copies or to make address changes, contact:

**China:** Chen Huaiwei, Institute of High Energy Physics, P.O. Box 918, Beijing, People's Republic of China  
**Germany:** Gabriela Heessel or Astrid Nagel, DESY, Notkestr. 85, 22603 Hamburg 52  
**Italy:** Mrs Pieri or Mrs Montanari, INFN, Casella Postale 56, 00044 Frascati, Roma  
**United Kingdom:** Su Lockley, Rutherford Appleton Laboratory, Chilton, Didcot, Oxfordshire OX11 0QX  
**USA/Canada:** Janice Voss, Creative Mailing Services, P.O. Box 1147, St Charles, Illinois 60174. Tel. 630-377-1589. Fax 630-377-1569

**Published by:** European Laboratory for Particle Physics, CERN, 1211 Geneva 23, Switzerland. Tel. +41 (22) 767 61 11  
 Telefax +41 (22) 767 65 55

**USA:** Controlled Circulation Periodicals postage paid at St Charles, Illinois

**Printed by:** Warners (Midlands) plc, Bourne, Lincs, UK

© 1999 CERN

ISSN 0304-288X



# CERN COURIER

VOLUME 39 NUMBER 3 APRIL 1999

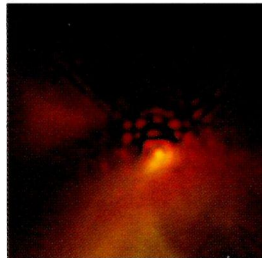

Dust orbiting a Taurus star p11

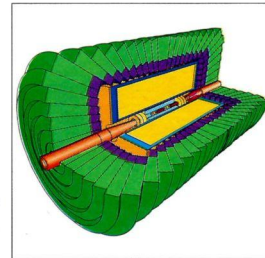

Detector for collider p19

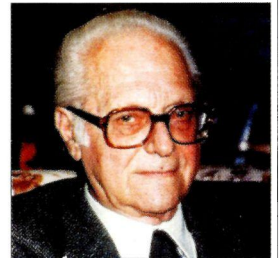

Edoardo Amaldi p37

## News

*New Fermilab director. CP violation picture gets clearer. HERA strikes it RICHER. Historic hardware. Roman pots for the LHC.*

5

## Astrowatch

**Features**  
**Superstrings, black holes and gauge theories**

*Yaron Oz describes how new geometry promises fresh understanding*

11

13

## Linear collider physics: the next challenge

*David Miller looks at the role of a linear electron-positron machine*

18

## KamLAND: neutrinos from heaven and Earth

*Giorgio Gratta looks at a new neutrino project in Japan*

22

## Silicon detectors: pushing up daisies or coming up roses?

*Looking at ways of making semiconductors more robust*

25

## Probing the pomeron

*Sandy Donnachie explains what controls high-energy scattering*

29

## Recruitment

32

## Bookshelf

37

## People

38

## Obituaries

39

**Cover:** Roman relics found during excavations at CERN prior to the commencement of major civil engineering work for the LHC collider. The coins suggest that building of another kind was under way towards the end of the third century AD. Some of the coins were minted in London, showing that the European monetary spirit was alive 1700 years ago. The LHC experiment to be mounted on the site will include what physicists call "Roman pots", this time packed with high technology. See "Roman pots for the LHC" p9.

# Engineered from the outside in.

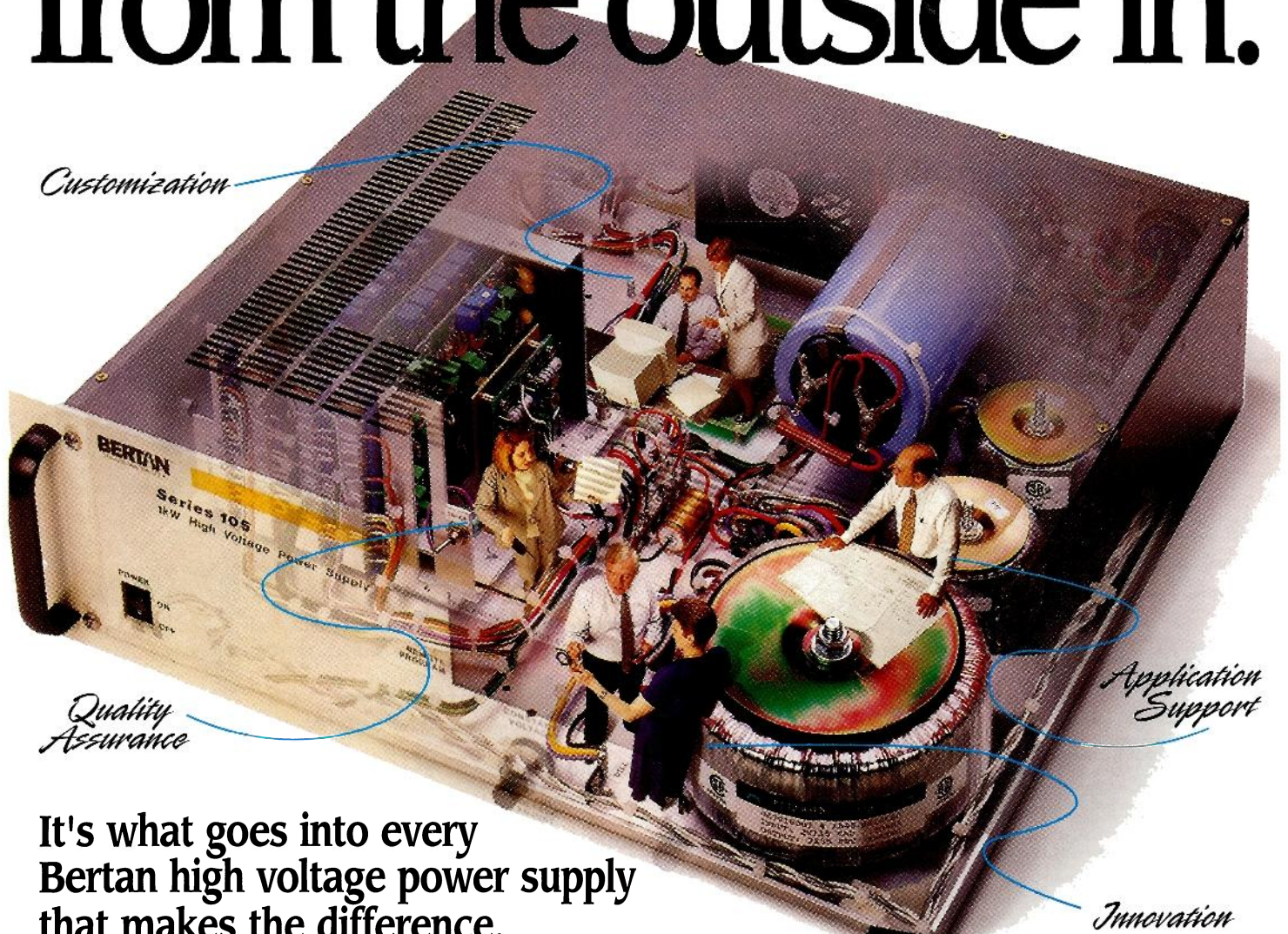

*Quality Assurance*

*Application Support*

*Innovation*

## It's what goes into every BERTAN high voltage power supply that makes the difference.

Highly qualified engineering and manufacturing professionals. The most skilled technical staff in the field. Extensive research and development. Rigorous testing procedures. A fully-staffed customer service organization and an extensive network of technical sales representatives.

Because every area of our organization is fine tuned to deliver the very best, our precision high voltage power supplies have earned the reputation of being the very best.

No wonder so many laboratories and OEM's turn to Bertan for solutions. They know our custom and standard

high voltage products are perfect in a wide array of scientific, analytical, medical, industrial and laboratory applications.

For the inside story on Bertan high voltage power supplies, call the "high voltage people" and ask for our free reference manual and catalog or visit our web site.

VOLTAGE . . .	500V to 120KV
CURRENT . . .	100µA to 1A
RIPPLE . . . .	<.001% p-p
POWER . . . .	1W to 1.2KW
PACKAGE . . .	Rack, Benchtop Module, NIM, PCB
DESIGN . . . .	Standard or Custom



# BERTAN™

**The high voltage people.**

121 New South Road, Hicksville, NY 11801  
Toll Free 800-966-2776  
Tel.: 516-433-3110 Fax: 516-935-1544  
[www.bertan.com/sales@bertan.com](http://www.bertan.com/sales@bertan.com)



Bertan is a Del Global Technologies company and a member of the Del Power Conversion Group. For more information about the Del Power Conversion Group, including Del Electronics, RFI, DynaRad and Bertan High Voltage, call 1-800-966-2776 or visit our web site at [www.delpower.com](http://www.delpower.com)

# Michael Witherell to direct Fermilab

Michael Witherell, from the University of California, Santa Barbara, will succeed John Peoples as director of Fermilab on 1 July.

The search for a new Fermilab director began last year, when John Peoples announced his intention to step down on 30 June 1999.

Michael Witherell earned his PhD at Wisconsin in 1973. He was assistant professor at Princeton from 1975 to 1981 and then moved to the University of California, Santa Barbara, where he was appointed professor in 1986.

His work in the 1980s on a Fermilab charm experiment brought him the prestigious

W K H Panofsky Prize in 1990. He was elected to the National Academy of Sciences last year. Since 1993 he has been working on the design and construction of the BaBar experiment at the Stanford Linear Accelerator Center, SLAC.

Over the past three years, Witherell has chaired the High-Energy Physics Advisory Panel (HEPAP), which advises the US Department of Energy on funding for particle physics.

*Michael Witherell of Santa Barbara succeeds John Peoples as Director of Fermilab. (Photo: Djamel E Ramoul.)*

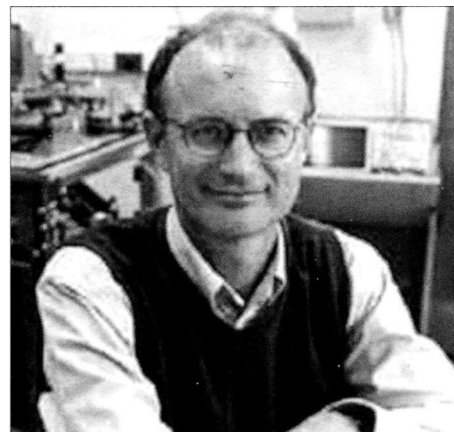

## CP violation gets clearer

New data from the KTeV experiment at Fermilab blow away some of the fog around the mystery of CP violation and underline the effects suggested by earlier results from CERN. It is now clearly established that CP is violated in the way the six known quarks decay and transform into each other.

In 1956, physicists were shocked to discover that the weak force is sensitive to direction and can differentiate left from right. With theoretical foundations crumbling, physicists proposed a new girder to support their theories: this time the combined CP symmetry mirror that changes particles to antiparticles as it reflects from left to right. In the CP mirror, a right-handed particle reflects as a left-handed antiparticle, and vice versa.

If CP symmetry is good, the neutral kaon should exist in two forms: a longlived one decaying into three pions, and a shortlived one decaying into two pions. In 1964, physicists received another shock when they found that, in the decays of the neutral kaon, CP too is violated. Longlived kaons can decay into two pions.

There are two possible explanations for this CP violation. The longlived kaon could be a mixture of two states that are even and odd under CP reflection. This has long been known to be the case: the even-CP state can decay

into two pions and introduce a CP-violating component for the longlived kaon.

The other possibility, called direct CP violation, is that the CP-odd state decays directly into the "forbidden" two-pion mode.

What causes the kaon states to mix CP? Using the six known quarks, this can be accommodated in the quark transformations, which subtly rearrange the incoming and outgoing quark configurations, switching a neutral kaon to its antiparticle. However, CP mixing could also be due to kaons transforming into each other via some other mechanism. In this case, direct CP violation -

CP violation in the decay process - would not be possible.

To unravel these two alternatives demands the careful measurement of direct CP violation via the "ratio of ratios": the ratio of longlived kaons decaying into two neutral pions to those going into two charged pions, divided by the same ratio for shortlived kaons. If this ratio of ratios turns out to be different from one, this demonstrates that quark transformations are responsible for CP violation.

For several years the two main experiments - NA31 at CERN and E731 at Fermilab - begged to differ, the former giving the difference of the ratio from unity (divided by a numerical factor) of  $2.3 \pm 0.65 \times 10^{-3}$ , and the latter giving a much smaller figure, compatible with zero. Physicists held their breath.

Now the KTeV experiment, using 20% of its data collected in 1996 and 1997, comes in at  $2.8 \pm 0.41 \times 10^{-3}$ , in tune with the earlier CERN figure, but slightly higher. CP would appear to be violated directly in the decay process in such a way that quark mechanisms contribute.

Meanwhile, the big NA48 next-generation CERN study has been collecting data and will be the next to report. Some 35 years after its discovery, CP violation remains a mystery, but at least the mystery is gradually becoming clearer. The new result is good news for new experiments setting out to measure CP violation using B particles, containing the fifth, "beauty", or "b", quark, where the levels of CP violation are now expected to be much higher than those using neutral kaons.

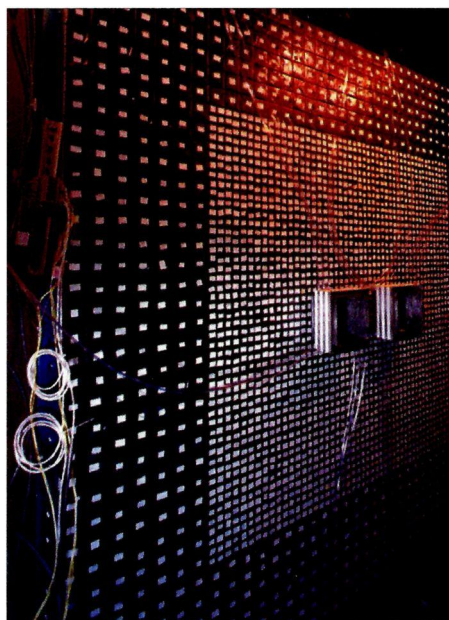

*Fermilab's KTeV experiment - contribution to CP violation.*

# MAKE YOUR PCI TO PCI CONNECTION PAINLESS WITH THE PVIC INTERCONNECTION SYSTEM

AVAILABLE IN:

COMES WITH LIBRARIES OR DRIVERS FOR  
WINDOWSNT, DIGITAL UNIX, IRIX, SOLARIS,  
VxWORKS, LYNX-OS, MACOS AND CHORUSOS™

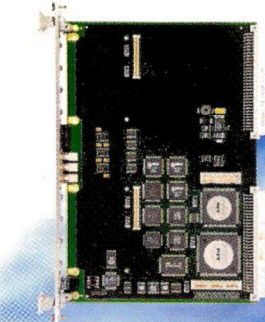

PVIC 8426 / 8025: PVME FORM FACTORS



PVIC 4425: COMPACTPCI™ FORM FACTOR

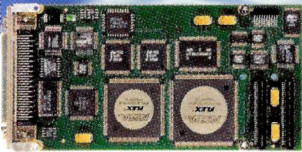

PVIC 8425: PMC FORM FACTOR

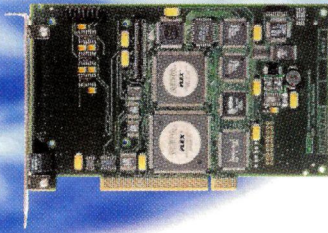

PVIC 7225: PCI FORM FACTOR FOR WORKSTATIONS

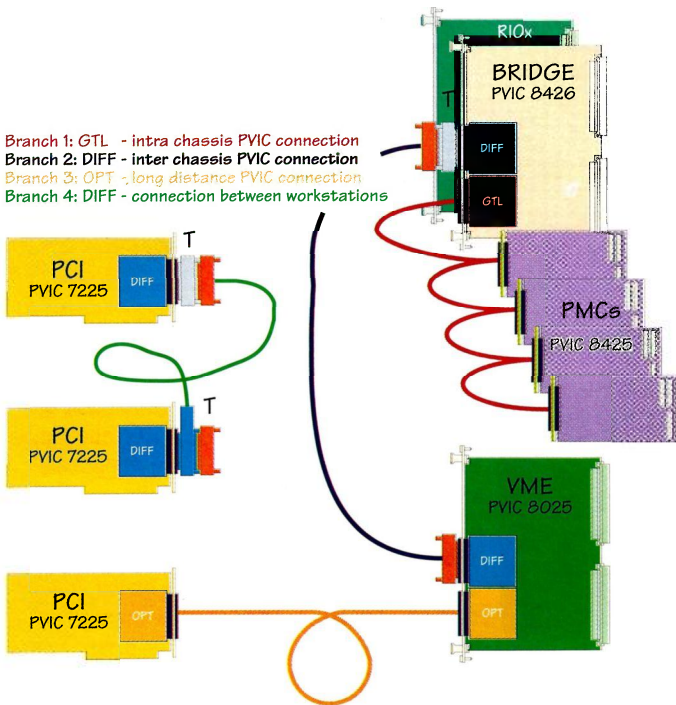

An example of mixed configuration: GTL - DIFF - OPT

- A TOTALLY TRANSPARENT PCI CONNECTION
- UP TO 15 NODES AND 30 METERS (COPPER) OR 200 METERS (FIBRE OPTIC)
- CONNECTION AT FULL PCI SPEED
- CONNECTION SPEED INDEPENDENT OF THE DISTANCE
- ZERO LATENCY
- UNIQUE SET OF ADVANCED BROADCAST MODES
- ON-BOARD CHAINED DMA MECHANISMS:  
SUSTAINED DATA AT 80 MBYTES/S UNDER OS
- ADVANCED INTER-PROCESSOR COMMUNICATION MECHANISMS:  
REMOTE INTERRUPTS, SEMAPHORES, MESSAGE QUEUES
- DRIVER ONLY REQUIRED FOR INTERRUPT HANDLING



*Your Real-Time Partner*



CES Geneva, Switzerland Tel: +41-22 792 57 45 Fax: +41-22 792 57 48 EMail: ces@ces.ch  
CES.D Germany Tel: +49-60 55 4023 Fax: +49-60 55 82 210  
CES Creative Electronic Systems SA, 70 Route du Pont-Butin, CH-1213 Petit-Lancy 1, Switzerland  
Internet: <http://www.ces.ch>



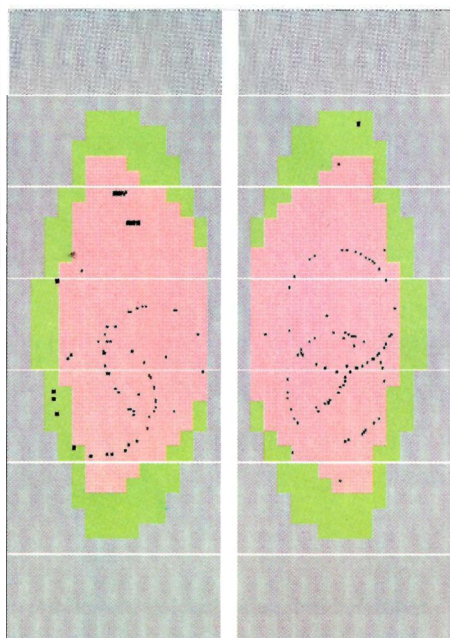

On-line display of a "typical" Ring Imaging Cherenkov event from the HERA-B experiment at DESY, Hamburg. Upper and lower arrays of photomultipliers are shown: the optical system is split in the plane of the HERA proton beam, sending Cherenkov photons to either detector array. One of the rings has photons that are shared by both arrays. The photomultiplier hits are represented as black squares. The inner region (pink) is covered by 16-channel photomultipliers, with coarser 4-channel tubes outside (light-green region). There are 26 816 single-photon detector channels in the system.

## HERA strikes it RICHER

The article "HERA strikes it RICH" in the November 1998 issue (p10) described the first rings seen in the Ring-Imaging Cherenkov (RICH) being commissioned for the HERA-B experiment at the HERA electron-proton collider at DESY, Hamburg.

In those early days, moist Hamburg air served as the Cherenkov radiator, but over the end-year shutdown the 100 cubic-metre RICH vessel was filled with  $C_4F_{10}$  gas, which is ten times as dense as air.

The greater density has three related consequences:

- Cherenkov rings from highly relativistic particles more than double in size;
- more than four times as many photons contribute to the characteristic rings (proportional to the square of the Cherenkov angle);
- the threshold momentum for producing Cherenkov light is reduced by the same factor of two.

The first events with the 920 GeV HERA proton beam in January dramatically confirmed these expectations. Because of the RICH optics design, some rings have photons detected on both the upper and the lower photomultiplier arrays. One of the rings is smaller than the others, showing that it comes from slower particles.

The design and construction of the gas circulation and purification system for the HERA-B RICH relied heavily on expertise from CERN. The groups responsible for the HERA-B RICH project consist of the University of Texas at Austin; the University of Barcelona; the University of Coimbra in Portugal; Northwestern University; the University of Houston (incorrectly indicated in the November article); the J Stefan Institute; and the University of Ljubijana, Slovenia. Support was provided by DESY and the University of Hamburg.

## Another way to get RICH

A prototype detector for the ALICE experiment at CERN's LHC collider will be installed in the STAR detector at Brookhaven's RHIC heavy ion collider, scheduled to come into action this year. ALICE will concentrate on heavy ion collisions at the LHC, and this way the proto-

type detector will have a foretaste of high energy heavy ions.

The ALICE detector involved is the High Momentum Particle Identification system, based on the Ring Imaging Cherenkov (RICH) technique.

## Historic hardware

In 1983 the big UA1 and UA2 experiments at CERN revealed the long-awaited W and Z particles, the carriers of the weak force. UA1, UA2 and much of CERN's antiproton infrastructure are no more, but CERN's Microcosm exhibition centre is preserving some of this historic hardware and transforming it into the focus of a new Hunting the Bosons exhibition.

A particle's-eye view through the central detector of the UA1 experiment – a feature of the new Hunting the Bosons exhibition at CERN's Microcosm exhibition centre.

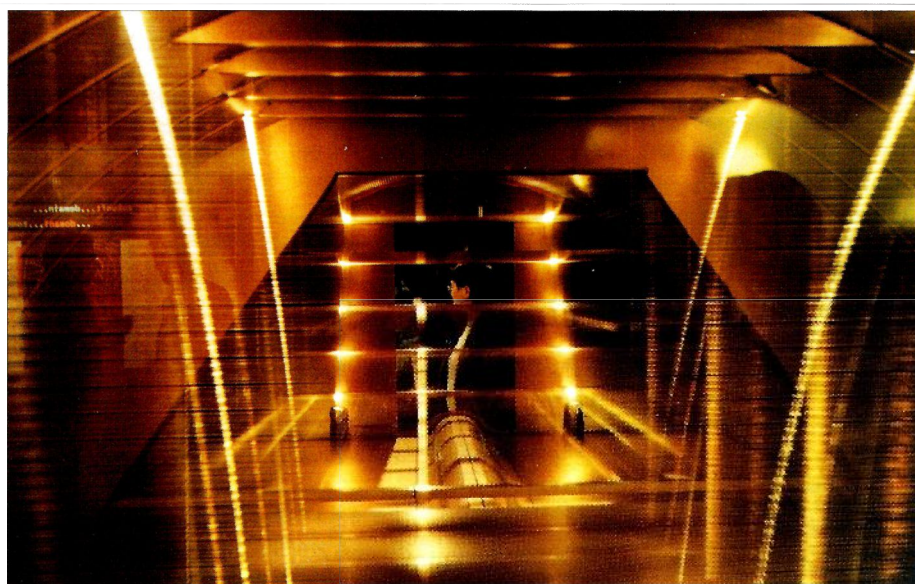

# All-metal Gate Valves

compact • reliable • unique

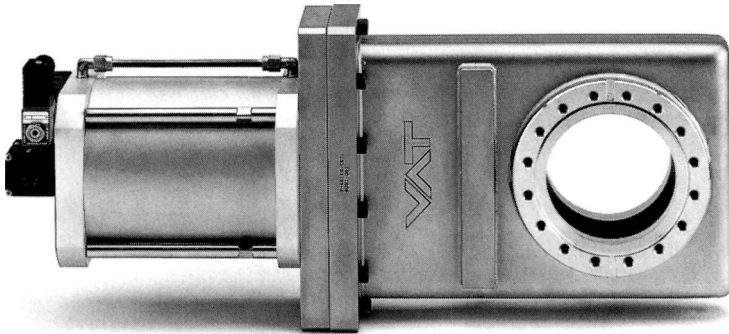

- the worldwide proven standard, industrially manufactured (ISO 9001)
- full range from DN 16 to DN 400
- many options available, specials on request

#### Swiss Headquarters

Tel ++41 81 771 61 61  
Fax ++41 81 771 48 30  
Email reception@vat.ch

#### VAT France

Tel 01 69 20 69 11  
Fax 01 69 20 90 08  
Email france@vatvalve.com

#### VAT Germany

Tel (089) 46 50 15  
Fax (089) 46 37 65  
Email vatdeu@t-online.de

#### VAT U.K.

Tel 0990 134 872  
Fax 0990 133 335  
Email info@vat-vacuum.co.uk

#### VAT Japan

Tel (045) 333 1144  
Fax (045) 333 7024  
Email info@vatskk.co.jp

#### VAT USA

Tel (781) 935 1446  
Fax (781) 935 3940  
Email usa@vatvalve.com

Visit our website at  
[www.vatvalve.com](http://www.vatvalve.com)

Y1956/11/14

## Single-Pass BPM

For linacs, synchrotrons, cyclotrons



$$X = -0,00012$$

$$Y = +0,00008$$

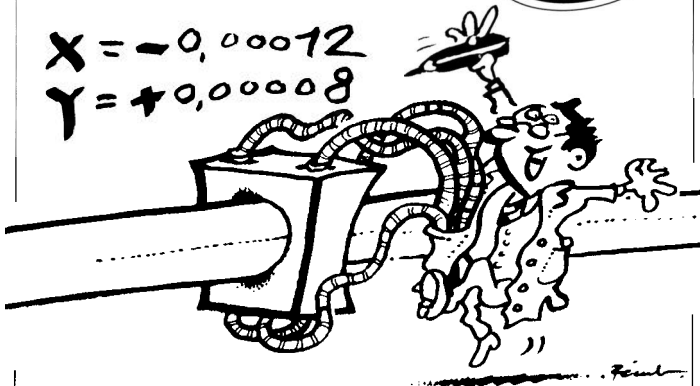

4 input channels processed simultaneously  
Log-ratio most recent amplifiers provide large dynamic range  
Direct X and Y outputs  $\pm 10V$   
Fast response time. Good for beam interlock  
Adapts to all pick-ups: selective filters and preamplifiers

Best of both worlds ! In parallel with our multiplexed BPM  
Get sub-micron position and single bunch too !

[www.bergoz.com](http://www.bergoz.com)



Instrumentation

Espace Allondon Ouest  
156 rue du Mont-Rond  
01630 Saint Genis-Pouilly, France  
info@bergoz.com

High-Tech Superconductors produced by  
a world leading industrial Group

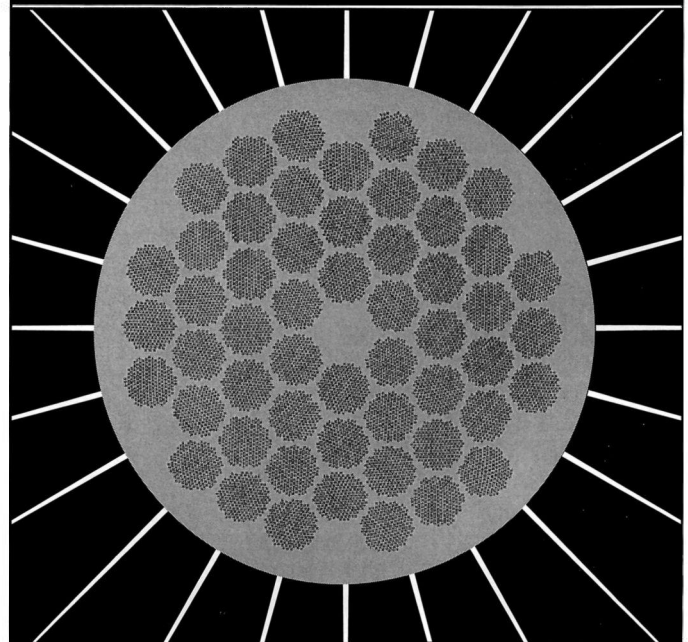

LARGE SCALE PRODUCTION OF:

- Nb/Ti and Nb<sub>3</sub>Sn wires
- Rutherford cables
- Coextruded Al stabilized cables
- CIC with Al alloy and stainless steel jackets
- High temperature superconductors

**EM**

Europa Metalli S.p.A.  
Superconductors Division

55052 FORNACI DI BARGA (Lucca) - Italy  
Phone ++ 39 0583-701.470/701.473  
Fax ++ 39 0583-701.471



## Roman pots for the LHC

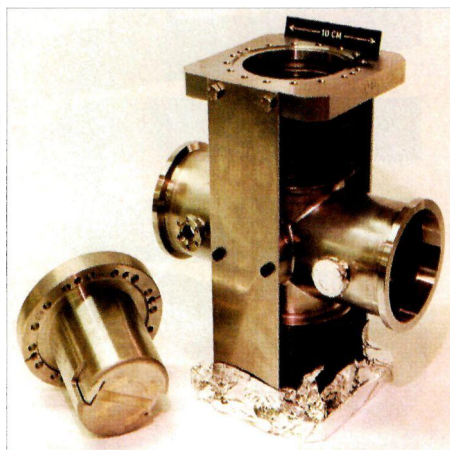

*In the Roman Pot technique, the detectors are placed as close to the colliding beams as possible. The pots, which are mounted on either side of the horizontal beam pipe, move vertically in a bellows structure towards the path of the colliding particle beams. One of the pots housing the detectors is shown (left) removed from the bellows structure.*

The "Roman pot" technique has become a time-honoured particle physics approach each time a new energy frontier is opened up, and CERN's LHC proton collider, which can attain collision energies of 14 TeV, will be no exception. While other detectors look for spectacular head-on collisions, where fragments fly out at wide angles to the direction of the colliding beam, with Roman pots the intention is to get as close as possible to the beams and to intercept particles that have been only slightly deflected.

If two flocks of birds fly into each other, most of the birds usually miss a head-on collision. Likewise, when two counter-rotating beams of particles meet, most of the particles are only slightly deflected, if at all. Paradoxically, most of the particles in a collider do not collide. Of those particles that do, many of them just graze past each other, emerging very close to the particles that are sailing straight through.

These forward particles are also important for measuring the total collision rate (cross-section). In the same way as light diffracting around a small obstacle gives a bright spot in the centre of the geometric shadow, so the

wave nature of particles gives a central spot of maximum "brightness".

To pick up these forward particles means having detectors that venture as near to the path of the colliding beams as possible, like avid spectators at a motor race leaning over the safety barrier. This is where Roman pots come in.

Why Roman? They were first used by a CERN-Rome group in the early 1970s to study the physics at CERN's Intersecting Storage Rings (ISR), the world's first high-energy proton-proton collider.

Why pots? The delicate detectors, able to localize the trajectory of subnuclear particles to within 0.1 mm, are housed in a cylindrical vessel. These "pots" are connected to the vacuum chamber of the collider by bellows, which are compressed as the pots are pushed towards the particles circulating inside the vacuum chamber.

The physics debut of these Roman pots was a physics milestone. Experiments at lower energies had found that the proton interaction rate was shrinking, and physicists feared that the proton might shrink out of sight at higher energies (p29). Using the Roman pots, the first experiments at the ISR were able to establish rapidly that the interaction rate of protons (total cross-section) in fact increases at the new energies probed by the ISR.

In their retracted position, the Roman pots do not obstruct the beam, thus leaving the full aperture of the vacuum chamber free for the fat beams encountered during the injection process. Once the collider reaches its coasting energy, the Roman pot is edged inwards until its rim is just 1 mm from the beam, without upsetting the stability of the circulating particles.

Each time a new energy regime is reached in a particle collider, Roman pots are one of the first detectors on the scene, gauging the cross-section at the new energy range. After the ISR, Roman pots have been used at CERN's proton-antiproton collider, Fermilab's Tevatron proton-antiproton collider and the HERA electron-proton collider at the DESY laboratory, Hamburg.

In the future, Roman pots will again have their day in the TOTEM experiment at CERN's LHC proton collider.

## Superconducting dipole magnet consortium

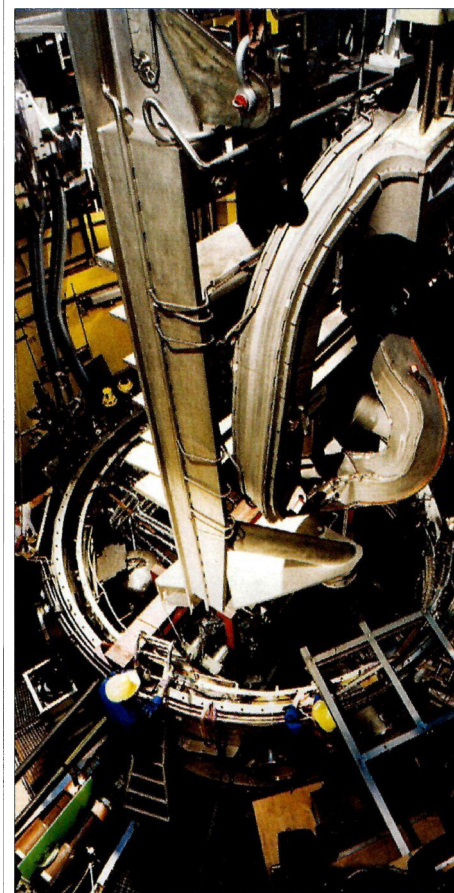

*Installation of the test cryostat for development work for superconducting magnets for the Wedelstein 7-X plasma experiment in Germany. The contract has been won by a consortium of Noell of Würzburg, Germany and Ansaldo of Genoa, Italy.*

Two of the initial firms supplying superconducting dipole magnets for CERN's LHC proton collider – Noell of Würzburg, Germany, and Ansaldo of Genoa, Italy – have joined forces to supply 50 superconducting magnets worth DM 110 million for the Wedelstein 7-X plasma experiment currently being built in Greifswald, Germany. Procurement is managed by the Max Planck Institute for Plasmaphysics in Garching, near Munich. Each of the superconducting coils weighs 3 tons and measures  $3.4 \times 2.5 \times 1.4$  m.

# Model magnet for CERN's LHC reaches 250 T/m in Japan

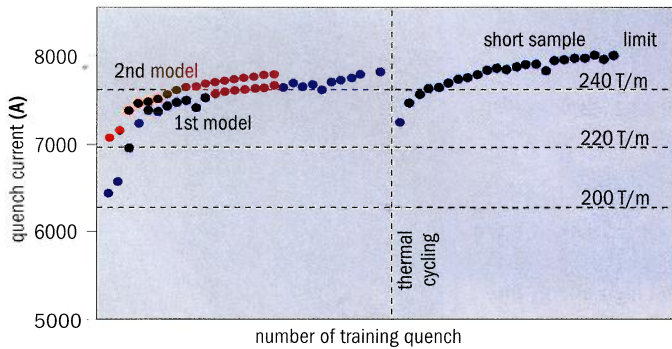

Training curves for superconducting magnets developed at the Japanese KEK laboratory for CERN's LHC collider.

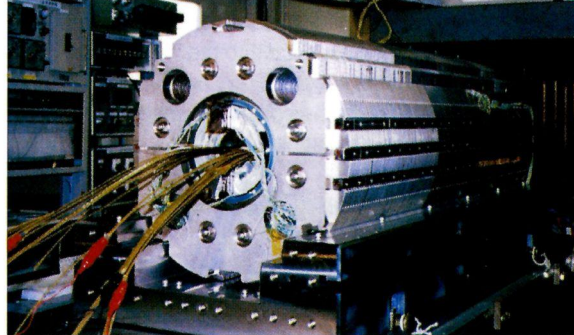

Japanese magnets for CERN's LHC – left, the cross-section of the short model, and right, the 1 m model assembly after the yoking process at the KEK laboratory.

Special superconducting quadrupole magnets for squeezing the beams at CERN's LHC collider have been successfully developed at the Japanese KEK laboratory as part of the LHC co-operation programme between CERN and KEK.

Since 1997, two model magnets have been made. The first reached the maximum operational field gradient of 220 T/m at the third training quench and has successfully achieved the maximum field gradient of 250 T/m at 1.9 K after thermal cycling and training. The second model reached 222 T/m at the first quench.

KEK has undertaken to provide magnets for the inner triplets, which provide the final focusing of the LHC beams for the four planned major experiments: ATLAS, CMS, LHC-B and ALICE.

KEK and Fermilab will each provide 16 of the 32 magnet cold masses, and Fermilab will be further responsible for the integration of the magnets within the cryostats.

The magnet features a high design field gradient of 240 T/m and a large coil aperture of 70 mm, and it must provide long-term stable operation at 200–220 T/m under the heat owing to lost particles and showers from the colliding beams.

The magnet consists of four-layer coils wound with NbTi/Cu compacted strand cables closely surrounded by an iron yoke to maximize the magnetic field, and also to function as the mechanical structure that supports the electromagnetic force.

The field quality of the model magnets has also been evaluated and the measurements indicated a necessary adjustment of the two-dimensional design of the coil to reduce the 20-pole component, according to the recent study of the beam dynamics carried out by the US team.

A third 1 m model is being developed to finalize the design. The full-scale prototype magnet programme will begin this year and extend to full production by 2001.

## The complete



## development environment

IRIS Explorer is the state-of-the-art, interactive 3D application development system for all your visualisation needs.

Enabling simple and complex, multi-dimensional datasets to be easily accessed, manipulated, visualised and animated, IRIS Explorer gives you greater insight into your data, delivering intelligent decisions faster.

Using this powerful, intuitive software is easy. By simply selecting building blocks and connecting them together using IRIS Explorer's point-and-click interface, you can rapidly design and customise visualisation applications without writing a single line of code.



All trademarks are acknowledged.

To find out how IRIS Explorer can increase your analysis capabilities, or to arrange a demo copy, contact NAG today: <http://www.nag.co.uk/iriscc>

### IRIS Explorer™

From data to understanding using visualisation.



email: [sales@nag.co.uk](mailto:sales@nag.co.uk)  
Tel: +44 (0)1865 511245

Edited by Emma Sanders

# Tantalum detector

A new development in detector technology is good news for astronomers. Designed by a team in the space science department of the European Space Agency's Science and Technology Centre, the detector saw first light earlier this spring at the William Herschel Telescope on La Palma.

The detector is based on an array of tantalum superconducting tunnel junctions (tantalum is a metal from the same family as niobium) and it operates at about 0.3 K. The instrument is interesting to astronomers because it allows single photon counting, imaging capability and the possibility to determine the energy of the incoming photon, all at the same time.

The detector has a count rate capability of 1 kHz and time tags the arrival of each photon to an accuracy of 5  $\mu$ s using the Global Positioning System as reference.

In the past, astronomers used gratings to achieve high-energy resolution. However, this dispersed the light and reduced efficiency. Now they will be able to determine the energy of photons without losing light.

Testing at the William Herschel Telescope was carried out at optical wavelengths, with an array of  $6 \times 6$  junctions, each with a field of view of 0.6 arcsec. The detector works equally well for radiation up to 1 keV X-rays, where an energy resolution of 5 eV has been obtained.

Superconducting tunnel junction (STJ) devices can also be used for building very sensitive amplifiers (SQUID circuits), and STJ logic circuits have applications in ultrafast signal processors. They only work in zero or fixed, low magnetic fields, however.

The development is the culmination of more than 10 years of R&D in collaboration with European industry.

## ESO update

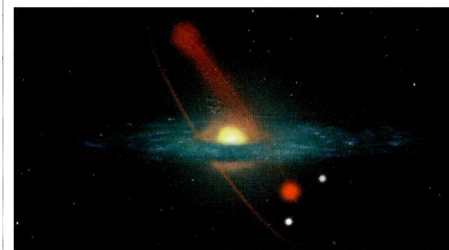

Artist's impression of a star cluster orbiting the Milky Way, losing stars as it goes. (ESO.)

The first 8.2 m telescope of the Very Large Telescope array opens to astronomers on 1 April. It has already made interesting discoveries during its commissioning stage.

Observations of one of the star clusters orbiting the central region of our galaxy has revealed a surprisingly small number of light-weight stars. This unusual mass distribution is caused by the gravitational attraction of the Milky Way, which pulls stars into its halo – a kind of giant galactic plughole. This is the first time that the effect has been observed, and the results can be used to obtain information about the formation of our galaxy and the amount of dark matter in its halo.

Meanwhile, new equipment has been installed at ESO's other observatory at La Silla. FEROS (Fibre-fed Extended Range Optical Spectrograph) was used to measure the spectra of stars in the outer galaxy.

One star was found to contain an unexpectedly large amount of lithium. This is interesting to cosmologists because lithium is the heaviest element created in measurable quantities after the Big Bang, heavier elements being created by nucleosynthesis in stars.

A star of this age and kind would normally have lost lithium. The excess is a mystery, which astronomers may have to wait for the VLT to solve.

## Picture of the month

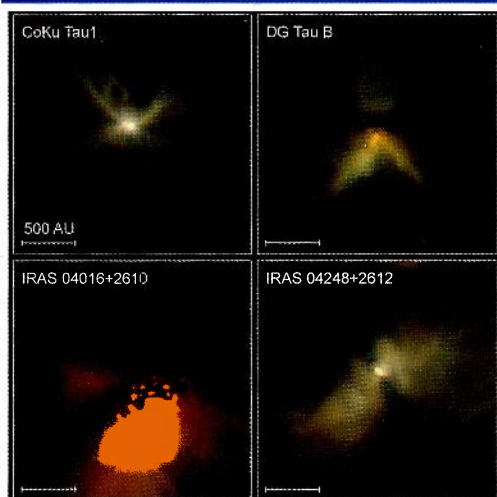

These young stars are in Taurus constellation, 450 light years away. Taken with the Hubble Space Telescope, the pictures show discs of dust orbiting the central star. The discs will condense to form planets. From the images, astronomers can calculate how much material is in the disc and study the dust's chemical composition to learn about planetary formation. More than a dozen possible extrasolar planets have been discovered, yet none has been directly imaged. The bright star overpowers the planet's reflected light. (Pic: NASA.)

## New light is shed on an old problem

For the first time, astronomers have recorded a gamma-ray burst at optical wavelengths. This is no mean feat. Although the bursts are extremely strong (up to 100 billion times as bright as ordinary stars), they occur without warning and last for typically a few seconds. Previous optical detection has been limited to images of the fading burst.

On 23 January, detectors onboard NASA's Compton Gamma Ray Observatory detected the beginnings of an intense burst. Immediately, the co-ordinates were forwarded to ground-based observatories around the world. Just 22 s later, astronomers at a small optical telescope at Los Alamos were on target. Slower off the mark, the mighty 10 m Keck II

telescope at Mauna Kea in Hawaii later pinpointed the fading burst and measured its distance to be around 9 billion light years.

The cause of gamma-ray bursts is a mystery. Candidates include merging black holes and hypernovae – massive exploding stars. The optical observations give astronomers a new insight into the processes at work.

Hear more next month at the Supernovae and Gamma Ray Burst Symposium at the Hubble Space Telescope Science Institute.

# VACUUMSOLUTIONS

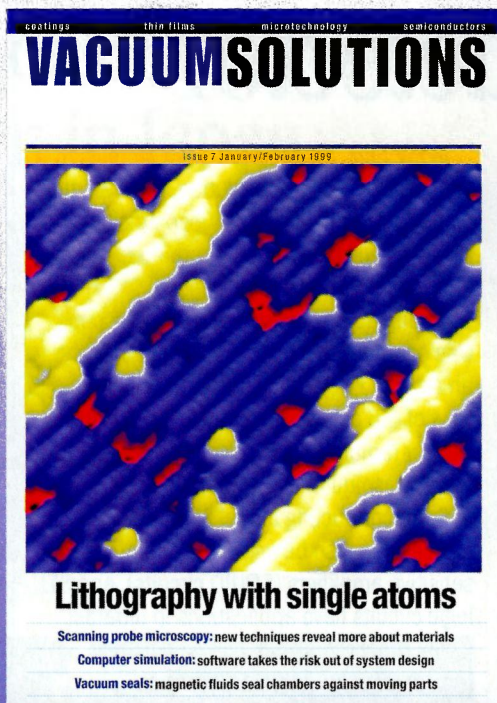

## The only magazine entirely devoted to the needs of vacuum users

If you work in vacuum, coatings, microtechnology, semiconductors or thin films, make sure you join the ever-growing number of professionals who rely on *Vacuum Solutions* for the very latest information relevant to their work.

Written by industry insiders and scientific experts, *Vacuum Solutions* is the dedicated publication highlighting the latest innovations that rely on the use of vacuum technology.

## Subscription Form

**Yes!** I would like to take out a subscription to *Vacuum Solutions*.

£48/\$90 6 Issues

£77/\$144 12 Issues **SPECIAL INTRODUCTORY OFFER – 20% DISCOUNT**

Cheques and money orders should be made payable to **IOP Publishing Limited**.

Please charge my Amex/Diners/Mastercard/Visa

Card No

Expiry Date

Please invoice me/my company

Name

Job title

Company

Address

Postcode

Country

E-mail

Tel. (inc. country and area code)

Fax (inc. country and area code)

Signature

Date

**Please return to:** *Vacuum Solutions* WDIS Ltd, Publishing House, Victoria Road, Ruislip Middlesex, HA4 0SX, United Kingdom

For fast service telephone the subscription hotline on +44 (0)181 845 8545 or photocopy and fax this to +44 (0)181 845 7696

CC0499

**If you have access to the Web you can complete the on-line form at <http://www.vacuum-solutions.com/subscribe.html>**

# Superstrings, black holes and gauge theories

Finding a quantum field theory that includes gravity has eluded the best minds of physics.

*Yaron Oz* of CERN explains how the theory of superstrings modifies classical geometry, and how the secrets of quantum black holes are encoded in quantum field theories.

Remarkable new developments show how physical field theories, such as that of quarks and gluons, can be related to gravity in higher dimensions.

Quantum field theories have had great success in describing elementary particles and their interactions, and a continual objective has been to apply these successful methods to gravity as well.

The natural length scale for quantum gravity to be important is the Planck length,  $l_p$ :  $1.6 \times 10^{-33}$  cm. The corresponding energy scale is the Planck mass,  $M_p$ :  $1.2 \times 10^{19}$  GeV. At this scale the effect of gravity is comparable to that of other forces and is the natural energy for the unification of gravity with other interactions. Evidently this energy is far beyond the reach of present accelerators. Thus, at least in the near future, experimental tests of a unified theory of gravity with the other interactions are bound to be indirect.

When we try to quantize the classical theory of gravity, we encounter short-distance (high-energy) divergences (infinities) that cannot be controlled by the standard renormalization schemes of quantum field theory. These have a physical meaning: they signal that the theory is only valid up to a certain energy scale. Beyond that there is new physics that requires a different description.

## Quantum gravity

Such a phenomenon is not unfamiliar. The short-distance divergences of Fermi's original theory of the weak interactions (with four particles meeting at one space-time point) signal that the description is only valid for energies less than the masses of the W and Z carrier particles. The divergences are resolved by introducing these particles in the Glashow-Salam-Weinberg theory.

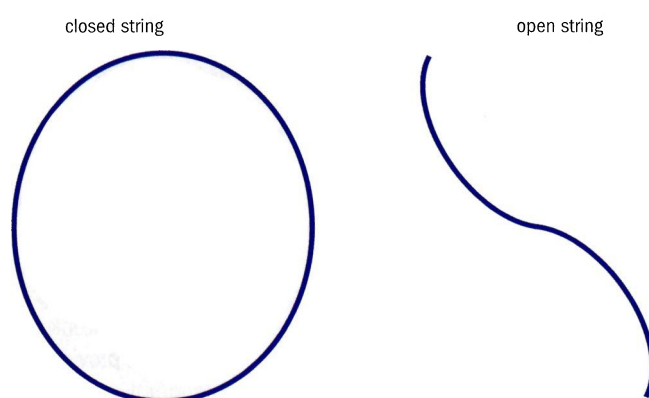

Fig. 1: Particles are the different vibrational modes of a string: either open or closed.

We expect that the divergences of quantum gravity would similarly be resolved by introducing the correct short-distance description that captures the new physics. Although years of effort have been devoted to finding such a description, only one candidate has emerged to describe the new short-distance physics: superstrings.

This theory requires radically new thinking. In superstring theory, the graviton (the carrier of the force of gravity) and all other elementary particles are vibrational modes of a string (figure 1). The typical string size is the Planck length, which means that, at the length

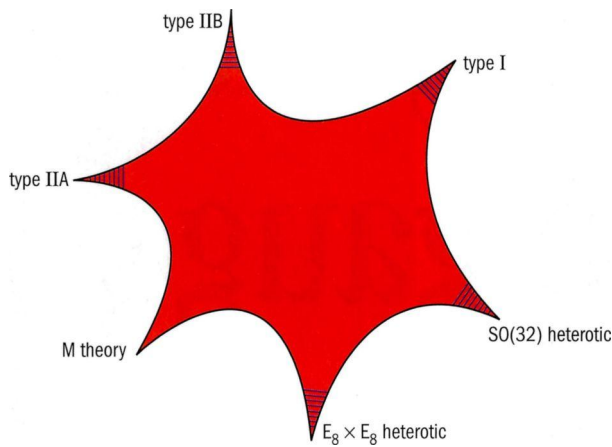

Fig. 2: The parameter space of the five consistent types of string theories. The edges are points where the corresponding string is weakly coupled. In the interior the coupling is generically of order 1. Also included is 11-dimensional M theory, which at low energies is described by 11-dimensional supergravity, a supersymmetric theory including gravity.

scales probed by current experiments, the string appears point-like.

The jump from conventional field theories of point-like objects to a theory of one-dimensional objects has striking implications. The vibration spectrum of the string contains a massless spin-2 particle: the graviton. Its long wavelength interactions are described by Einstein's theory of General Relativity. Thus General Relativity may be viewed as a prediction of string theory!

The quantum theory of strings, using an extended region of space-time, sidesteps short-distance divergences and provides a finite theory of quantum gravity. Besides the graviton, the vibration spectrum of the string contains other excited oscillators that have the properties of other gauge particles, the carriers of the various forces. This makes the theory a promising (and so far the only) candidate for a unification of all of the particle interactions with gravity.

In the absence of direct experimental data to confront string theory, research in this field is largely guided by the requirement for the internal consistency of the theory. This turns out to dictate very stringent constraints. Again, this is not unfamiliar to particle physicists. When resolving the short-distance divergences of Fermi weak interaction theory, the space-time and internal symmetries provide stringent constraints and guide us to the solution.

### Superstring theories

Two important features of string theory are implied by the consistency requirement. First, superstring theory is consistent only in 9+1 space-time dimensions. This seems to contradict the fact that the world that we see has 3+1 space-time dimensions. Second, there are five consistent superstring theories: Type IIA, Type IIB, Type I,  $E_8 \times E_8$  Heterotic and  $SO(32)$  Heterotic. Type I is a theory of unoriented open and closed strings; the others are theories of oriented closed strings. Which should be preferred?

All five possess supersymmetry, hence the name superstrings. According to supersymmetry theory, any boson (integer spin parti-

cle) has a fermionic (half-integer) superpartner and vice versa. One way to view supersymmetric field theories is as field theories in superspace – a space with extra fermionic quantum dimensions. Many physicists expect that supersymmetry exists at the tera electron volt scale, so that the new 'superpartner' particles could be seen by CERN's LHC proton collider.

### Compactification and stringy geometry

The time and the three spatial dimensions that we see are approximately flat and infinite. They are also expanding. Just after the Big Bang they were highly curved and small. It is possible that while these four dimensions expanded, other dimensions did not expand, remaining small and highly curved.

Superstring theory says that we live in 9+1 space-time dimensions, six of which are small and compact, while the time and three spatial dimensions have expanded and are infinite.

How can we see these extra six dimensions? As long as our experiments cannot reach the energies needed to probe such small distances, the world will look to us 3+1-dimensional and the extra dimensions can be probed only indirectly via their effect on 3+1-dimensional physics. It is not known at what energies the hidden compact dimensions will open up. The possibility that new dimensions or strings will be seen by the LHC is not ruled out by the current experimental data.

Superstring theory employs the Kaluza-Klein mechanism to unify gravitation and gauge interactions using higher dimensions. In such theories the higher dimensional graviton field appears as a graviton, photon or scalar in the 3+1-dimensional world, depending on whether its spin is aligned along the infinite or compact dimensions.

The number of consistent compactifications of the extra six coordinates is large. Which compactification to choose is the prize question. The answer is hidden in the dynamics of superstring theory. Using a limited (perturbative) framework, one can attempt a qualitative study of the 3+1-dimensional phenomenology obtained from different compactifications. It is encouraging that some of these compactifications result in 3+1-dimensional models that have qualitative features such as gauge groups and matter representations of plausible grand unification models. Interestingly the low-mass fermions appear in families, the number of which is determined by the topology of the compact space.

### T-duality

Not all of the compactifications are distinguishable. To illustrate this, take one spatial co-ordinate to be a circle of radius  $R$ . There are two types of excitations. The first, which is familiar from theories of point-like objects, results from the quantization of momentum along the circle. These are called Kaluza-Klein excitations. The second type arises from the closed string winding around the circle. These are called winding mode excitations. This is a new feature that does not exist in point-like theories. When we map the size of the radius,  $R$ , of the circle to its inverse,  $1/R$ , with the string scale set to one, the two types of excitations are exchanged and the theory remains invariant. There is no way to distinguish the compactification on a circle of radius  $R$  from a compactification on a circle of radius  $1/R$ . This means that the classical geometrical concepts break down at short

distances and the classical geometry is replaced by stringy geometry.

In physical terms, this implies a modification of the well known uncertainty principle. The spatial resolution,  $\Delta_x$ , has a lower bound dictated not just by the inverse of the momentum spread,  $\Delta_p$ , but also by the string size. The mapping of the radius of the compactification to its inverse, exchanging Kaluza–Klein excitations with winding modes, is called T-duality.

Another example of stringy geometry is “mirror symmetry”. In the previous example, both circles had the same topology and different sizes. In contrast, mirror symmetry is an example of stringy geometry where two six-dimensional spaces, called Calabi-Yau manifolds, with different topology are not distinguishable by the string probe.

### String duality and M theory

To select the “best” theory, we have to introduce the idea of S-duality. Consider a strongly coupled physical system. There may be another set of variables in which the system is weakly coupled. The transformation from one set of variables to the other is called S-duality. In practice it is usually impossible to find the exact change of variables from the strongly coupled degrees of freedom to the weakly coupled ones. Unlike T-duality, S-duality is non-perturbative. This prevents us from proving it, but we can accumulate enough evidence to convince ourselves of its existence.

A major discovery is that all five consistent string theories are related by dualities such as T- and S- dualities. This puts the five string theories in a unified framework – they are equivalent descriptions of the same physical system with different variables.

Figure 2 describes the parameter space of string theories – the edges are points where the corresponding string is weakly coupled. In the interior the coupling is generically of order 1. One additional item in figure 2 is 11-dimensional M theory, which at low energies is described by 11-dimensional supergravity, a supersymmetric theory including gravity.

Unlike string theory, M theory does not have a coupling constant. It is reduced under various compactifications to the five string theories. As an example, consider M theory compactified on a circle of radius  $R$ . This is dual to Type IIA string theory with the string coupling proportional to  $R$ . The strong coupling limit of 10-dimensional Type IIA string theory corresponds to a large  $R$  and, amazingly, another dimension opens up, so that it is described by 11-dimensional theory.

Not much is known about M theory. With no coupling constant there is no systematic perturbative expansion. One attempt to provide a non-perturbative definition is Matrix Theory, based on supersymmetric quantum mechanics of infinite matrices.

### Strings and quantum black holes

Classical black holes are completely black, swallowing whatever crosses their event horizon and emitting nothing. Hawking argued that quantum black holes emit radiation. This raises a long-standing puzzle. We can start with a pure quantum state to form a black hole and end with a mixed state of thermal radiation. This contravenes the basic rules of quantum mechanics. Black holes also carry entropy proportional to their event horizon. To understand these features of black holes requires a quantum theory of gravity, and string

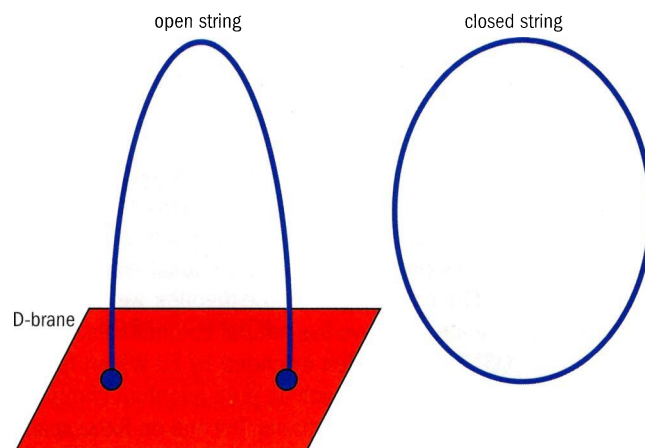

Fig.3: D-branes are non-perturbative excitations of string theory on which open strings can end. Open strings have gauge fields, so the D-branes define a gauge theory. There is a class of black hole made of D-branes, and these have a quantum gauge theory description. The closed strings define a field theory of gravity.

theory provides such a framework. The entropy of the black hole is a measure of how many quantum states it has. For certain black holes these can be identified as D-branes – non-perturbative excitations of string theory on which open strings can end. (D-branes provide Dirichlet boundary conditions for the strings; figure 3.)

Open strings have gauge fields, so the D-branes define a gauge theory. There is a class of black holes made of D-branes, and these have a gauge theory description of their quantum properties. For these black holes it is possible to count the microscopic quantum states and derive the Bekenstein–Hawking equation relating the black hole entropy to the area of the event horizon. It is also possible to compute the rate of Hawking radiation resulting from quantum scattering and give its microscopic explanation.

### Strings and gauge theories

For an ordinary quantum field theory of a physical system in a volume  $V$ , the number of degrees of freedom is proportional to the volume.

A quantum theory of gravity is believed to possess a remarkable property called holography, which was introduced by Gerard ‘t Hooft and Leonard Susskind. Here the number of degrees of freedom of a quantum gravitational system in volume  $V$  is expected to be proportional to the area of the boundary of the volume. This means that the physics of a quantum gravitational system in  $d+1$  dimensions is coded in a holographic way in  $d$  dimensions. As in an optical hologram, the information is coded in a complicated way.

Because string theory is our candidate for a theory of quantum gravity, it should exhibit such holography. This has been realized recently in Matrix Theory, and for strings on certain spaces with negative cosmological constant, known as Anti de Sitter spaces. “Holograms” are located on the boundaries of these spaces. In both cases the hologram that encodes the quantum gravity properties is a gauge theory. Remarkably, the secrets of the evaporation of quantum black holes are hidden in such a hologram – the strong

## Quantum gravity

coupling regime of quantum field theory.

On one hand the theory of D-branes is a gauge theory. On the other, D-branes are massive objects that curve the space-time in which they are embedded. The consideration of the D-branes from these two viewpoints led to a conjecture by Juan Maldacena (Harvard) on the duality between gauge theories and string theory on Anti de Sitter spaces.

Of particular interest is the equivalence between gravity in five dimensions and gauge theory in four. The additional fifth dimension corresponds to the energy scale of the four-dimensional quantum field theory. Just as theories of three spatial dimensions and one of time became four-dimensional space-time theories, we may be led to add the energy scale and have five natural co-ordinates.

The duality conjecture has been extended by Ed Witten to non-supersymmetric gauge theories, such as pure quantum chromodynamics (QCD) – the field theory of gluons. The Anti de Sitter spaces are now replaced by Anti de Sitter black holes. When the gravitational background is regular, the supergravity approximation of string theory can be used and exhibits the required properties of QCD, such as the colour confinement of quarks. To study QCD quantitatively requires singular gravitational backgrounds, and it seems that the key to long-standing questions, such as computation of the hadron spectrum, is hidden in the geometry of string theory.

### Unification

In the supersymmetric extension of the Standard Model, the strong and electroweak gauge couplings seem to unify at an energy of

$10^{16}$  GeV. The gravitational coupling does not unify with the others at this energy. Traditionally it is expected to unify at the Planck scale.

There is, however, another interesting possibility. The energy dependence of the gravitational coupling can be changed by using the extra dimensions. The unification energy of the gravitational coupling can be lowered if, as in the D-brane physics of figure 3, the gauge fields live in 3+1 space-time dimensions while the gravity also propagates in the other dimensions.

This can dramatically change the scales of string physics. The string scale cannot be less than 1 tera electron volt because string excitations have not been observed by accelerators. It is possible, however, that the string scale is at the tera electron volt scale, and that string excitations will be seen by the LHC. The compactification scale – the size of the largest compact dimension – can be even lower. Amazingly, it can be millimetre-sized.

Although this seems to be in contradiction with laboratory experience, in fact this is not the case. The gauge fields do not propagate in the compact dimensions, so they do not have Kaluza-Klein excitations. There are Kaluza-Klein excitations from the closed strings in figure 3, but they are weakly coupled and could not be observed. Larger dimensions are ruled out by experiments measuring gravitational effects at short distances.

The extra dimensions can be used to lower the unification energy so that a complete unification of all forces can occur already at tera electron volt energies.

Yaron Oz, CERN.

## Explore with us –

*In the laboratory, in outer space, or below the earth's surface.*

*Discover a scintillator to meet your requirements!*



**BICRON®**

Saint-Gobain Industrial Ceramics, Inc.



**crismatec**

A Saint-Gobain Company  
ISO 9001 Certified

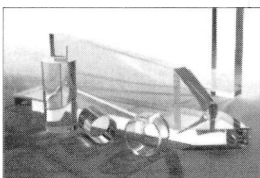

### High performance plastic scintillators

Custom assemblies,  
special formulations  
Cast sheets up to  
5 meters long

### Plastic scintillating fibers

Square and round  
cross-sections,  
250µm to 5mm

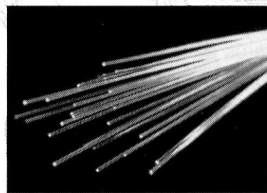

### Bicron

In USA: Phone: +1 440-564-2251 • Fax +1 440-564-8047  
In Europe: Phone: 31 (35) 60 29 700 • Fax: 31 (35) 60 29 214  
In Japan: Phone: 81 (45) 474 5786 • Fax: 81 (45) 474 5787  
Explore our web site: <http://www.bicron.com>

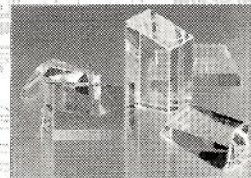

### High performance scintillation crystals

NaI(Tl), CsI(Tl),  
Pure CsI, CsI(Na),  
BGO, YAP:Ce ...

### Scintillation detectors

Standard and custom  
designs for medical,  
physics, industry,  
radiation protection and  
security applications

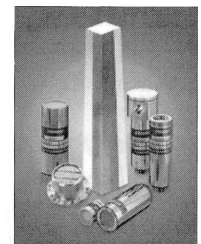

### Crismatec

104, Route de Larchant - 77140 Saint-Pierre les Nemours, France  
Phone: 33 (1) 64-45-10-10 • Fax: 33 (1) 64-45-10-01  
e-mail: [customer.service@crismatec.saint-gobain.com](mailto:customer.service@crismatec.saint-gobain.com)  
Explore our web site: <http://www.crismatec.com>

SAINT-GOBAIN  
INDUSTRIAL CERAMICS



# PhiTec AG

Engineering · Products · Systems



If you are looking for a  
**custom made**  
vacuum solution ?

A complete range of

**valves and vacuum  
components**

from HV to UHV for several applications as

**industrial vacuum  
accelerator plants  
space applications**

If you need such products

**we should talk !**

PhiTec AG  
P.O.Box  
CH-9468 Sax  
Switzerland

Tel +41 81 7504 111  
Fax+41 81 7504 100  
PhiTec@chgate.net  
www.phitec.ch

## Need to probe microstrip detectors or front-end VLSI's?

### Maehlum Instruments PS150 simplifies and speeds up the work.

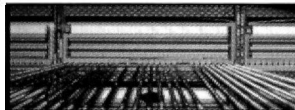

#### Applications:

Microstrip detectors  
front-end ASICs,  
materials research,  
Kapton interconnects,  
and so on.

#### Key specifications:

Ultra stable construction.  
150x150x12 mm movement.  
0.25µm resolution.  
LabView drivers.  
IEEE488, RS232 interface.  
Joy-stick manual control.  
300mm microscope travel.  
Accepts various microscopes.  
Accepts common probecards  
Custom designs possible.



## MI AS

Maehlum Instruments AS

phone: +47 22 58 01 32  
fax: +47 22 58 01 33

www.maehlum.com  
info@maehlum.com

Zero-flux™ measuring systems

## Reliability and accuracy

### SPECIAL MEASURING SYSTEMS

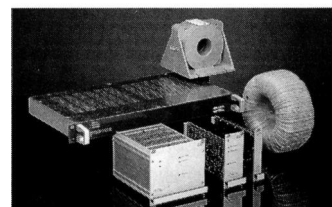

Sometimes a good eye and a steady hand are all you need. However, for measuring currents with high accuracy and reliability you need other qualities. You need a Zero-flux™.



## HITEC Power Protection

P.O. Box 4  
7550 GA Hengelo  
The Netherlands  
Phone: +31 74 246 28 53  
Fax: +31 74 246 26 78  
E-mail: sales@hitecsms.com

www.hitecsms.com

# Linear collider physics:

While CERN's LHC proton collider is the world's major particle physics project, other avenues of research could yield complementary studies. Here, *David Miller* looks at the possibilities for a linear electron-positron collider.

Competition is the lifeblood of science. We see this at every level. Just now there is intense competition between experiments at the Tevatron at Fermilab and those at LEP at CERN to make the most precise measurement of the mass of the W boson. On many other topics one or other of the two machines is the clear leader: only the Tevatron can make real top quarks, for instance, while only LEP can determine the couplings of the W and the Z bosons to a precision of a few parts per thousand.

CERN's next machine, the Large Hadron Collider (LHC), will collide protons at 14 TeV, an energy seven times as high as the Tevatron will ever reach, and at a much higher rate. The world's particle physicists agree that it is the right machine to build next, but it is surely not going to be the only future machine. There is a growing consensus that its competition must come from a linear electron-positron collider with an energy range from the top-antitop quark threshold (350 GeV) to somewhere near 1 TeV. Who will build it, and where, is another fascinating competition that will not be decided for a few more years. However, wherever it is built, there is a growing community of would-be users pushing for it.

Taking the Standard Model of particle physics at face value, recent fits to the precision data from LEP, Stanford's SLC and Fermilab show that the Higgs boson mass should be less than 300 GeV, within the reach of both the LHC and of a 500 GeV linear collider.

## Higgs boson

To see a real Higgs boson will be a great achievement, but we will immediately have to ask whether it has the properties predicted by the Standard Model. We expect a "light" Higgs (lighter than 140 GeV) to decay into photon-photon or into beauty quark-antiquark pairs. If it is heavier it should decay into pairs of W bosons, Z bosons or top quark and antiquark. The LHC would surely get into this region first, but it would not be able to measure some of the most basic Higgs properties, for instance its decay width - related to its lifetime by the Heisenberg principle.

A linear collider would be needed to do that, either producing the Higgs boson through its direct coupling to W bosons or, for a very

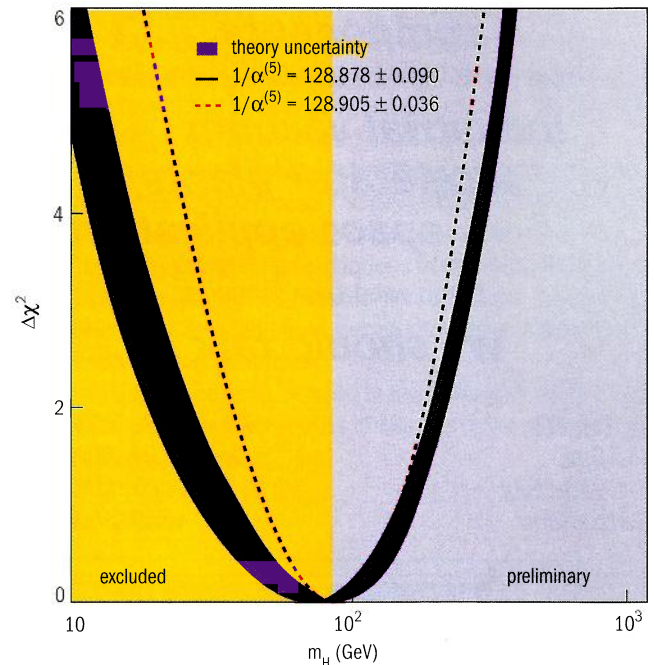

*If the Standard Model is right, the Higgs boson must be close! The curves from the LEP Electroweak working group show that the most probable mass for a Higgs boson, from fits to all available electroweak data, including the latest from LEP (CERN), SLD (Stanford) and the Tevatron (Fermilab), is approximately 90 GeV, and with 95% confidence below 250 GeV. The yellow area has already been eliminated by direct searches at LEP.*

light Higgs, by making Higgs bosons in real photon-photon collisions. A high-luminosity linear collider would also be needed to measure the coupling of the Higgs boson to the top quark.

In theories beyond the Standard Model there could be more than one Higgs boson. Minimal supersymmetric models need five, together with the supersymmetric partners of the Standard Model particles.

The precision of the linear collider would be essential in identifying the supersymmetric partner particles of the non-quark/gluon particles (those not carrying the interquark colour force) and making precise measurements of their masses. As its colliding protons contain quarks interacting through the colour force, the LHC will be better for identifying the partners of the quarks and gluons.

Between them the LHC and the linear collider should also be able to check whether the behaviour of the lightest supersymmetric particle is consistent with its being the main constituent of the missing

# the next challenge

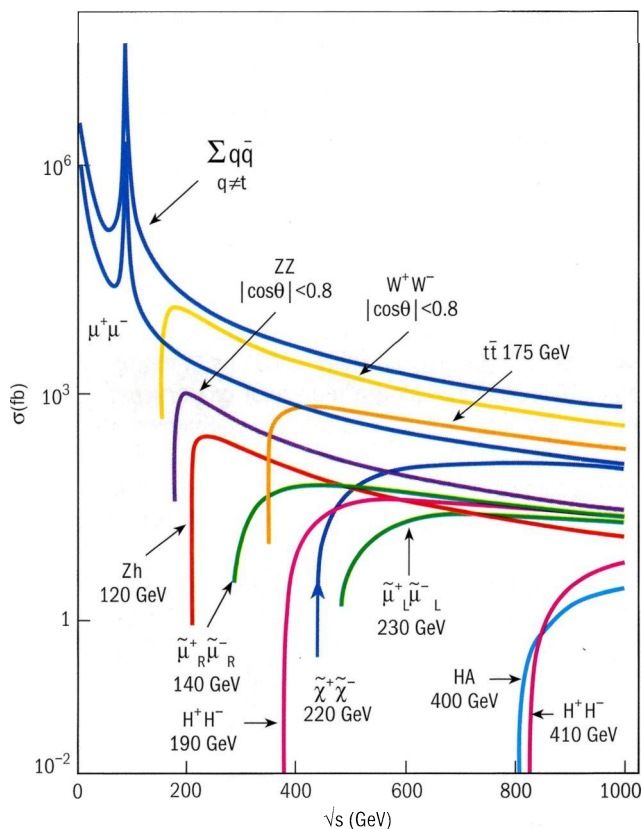

Production rates for possible states accessible at a linear collider. Some of the particles ( $W$ ,  $Z$ , top quark, muon) are established, some (various Higgs bosons,  $h$ ,  $A$ ,  $H$ ; supersymmetric particles – with squiggles on top) are predicted in wider theories. The horizontal axis is the energy that is available to make new particles in the electron-positron collision. The vertical axis is the cross-section in femtobarns (fb). The productiveness of a running period can be given by the number of events expected per femtobarn (events/fb, or inverse femtobarns). Linear colliders will produce between 50 and  $500 \text{ fb}^{-1}$  per year.  $50 \text{ fb}^{-1}$  at 500 GeV should produce about 3000 top quark-antiquark pairs. (Plot from the Japanese Linear Collider team.)

“dark matter” that astrophysics requires to explain the observed large-scale gravitational attractions.

As well as venturing into new physics, the linear collider should also make much improved measurements on the workings of established theory. Its energy can be scanned very carefully across the production threshold of top quark-antiquark pairs. Quantum

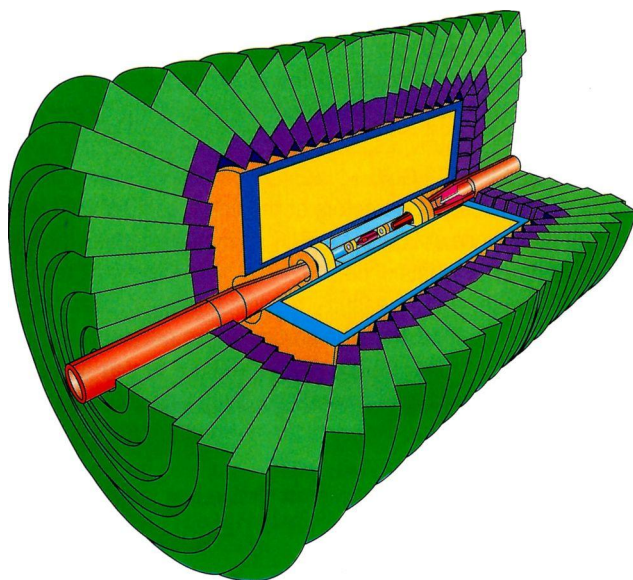

A cutaway illustration of the current European reference design for a detector at a linear electron-positron collider. The beams collide at the centre. Silicon tracking detectors packed close to the beam collision point measure the delayed decays of beauty and charm particles, which are definitely expected from top quark decays and are a very likely signature for most versions of Higgs boson decays. The large yellow space is the Time Projection Chamber where charged particles produce curved tracks in a magnetic field. The purple and green blocks are calorimeter modules that give electronic pulses proportional to the energies of the outgoing particles. The red plugs along the beam direction on both sides of the detector are tungsten “masks” to screen off background radiation that is produced when particles in one beam scatter on the electromagnetic fields from the other.

chromodynamics (QCD), the theory of quarks and gluons, makes very specific predictions for what happens at this threshold, and it should be possible to measure the top quark mass (near 175 GeV) to better than 175 MeV – much more precisely than the LHC. The top quark mass will then be proportionally far better known than that of any of the lighter quarks.

At a high-luminosity linear collider, the samples of light quark-antiquark events will match those from LEP1 and offer a chance to probe the evolution of QCD to higher energy scales. If real photon beams can be produced, then the linear collider will also probe the structure of the photon with the same sensitivity that is being achieved for the proton at the HERA electron-proton collider at

DESY, Hamburg, thereby testing more of the predictions of QCD.

Even if there is no Higgs boson and if supersymmetry does not appear, some new physics must still happen at the 1 TeV energy scale. There is no precise theory of what this new physics might be, but it would very likely increase the production of top quark-anti-quark pairs and of W and Z boson pairs.

Again, the LHC would see something, but it will take a lepton (non-quark) machine with collision energy in the 2-4 TeV region to sort out the full theory. This could be either a higher energy linear electron-positron collider or a muon collider. However, before then the linear collider in the 500 GeV - 1 TeV range should have seen the first signs of the new physics through increasing the precision of studies of W and Z couplings, already testing the Standard Model so stringently at LEP's 192 GeV.

To do the physics, the detectors at the linear collider will have to be better than those at LEP or the SLC. At higher energies there will be more and narrower jets of particles that have to be kept separate, so the calorimeters that measure the directions of energy flow will need to be finer-grained. It will be particularly important to measure the pairs of electrons or muons from Z decays to see a recoiling Higgs boson in annihilations producing a Higgs and a Z. This requires a good particle tracker to measure the momentum from the curvature of the outgoing electrons or muons.

In European studies, the tracker of choice has been a Time Projection Chamber, like that in ALEPH or DELPHI at LEP, with much

**The new physics will emerge from individual high-energy electrons and positrons colliding, but while these clean events are happening the two beams will be interacting in other "dirty" ways.**

higher performance and a 3 Tesla magnetic field. Alternatively, in a 1996 study at Snowmass, the North Americans considered an all-silicon tracker - like that planned for the ATLAS experiment at the LHC - with a magnetic field of 4 Tesla. The first tracker design from Japan used a large "jet" drift chamber, similar to those in OPAL, or L3 at LEP and SLD at Stanford. Work has

already begun on new inner (vertex) detector techniques for the linear collider, using charge-coupled devices or "smart pixels".

The biggest differences between the detectors for the linear collider and those at LEP will be in the forward directions, close to the colliding beams. The beams meeting head-on at a linear collider have to be compressed into tiny "rods" (with a cross-section of around  $10 \times 500$  nm - almost molecular proportions - compared with tens of microns at LEP) so that the collision rate (luminosity) produces useful numbers of events. Each bunch in the beam contains some  $10^{10}$  electrons or positrons travelling at close to the speed of light, and producing very strong electric and magnetic fields.

The new physics will emerge from individual high-energy electrons and positrons colliding, but, while these clean events are happening, the two beams will be interacting in other "dirty" ways - deflecting and disrupting one another, and producing background radiation when particles in one beam scatter on the electromagnetic fields from the other.

To keep this radiation away from the tracking detectors, thick conical tungsten "masks" will be fitted in the forward regions. These will prevent precise measurements on small angle tracks, though it is hoped to develop techniques (perhaps with quartz fibres buried in the tungsten to produce detectable pulses of light when particles pass through) so that at least it will be known whether any tracks from an interesting event went into a mask.

Significant detector R&D will be needed, but there is no doubt that the experimental environment will be easier than at the LHC, with fewer background events and less radiation hitting the detectors. If the collider can be funded and built then the physics can be done. And although many of the goals are complementary to those of the LHC, there will be real competition too.

### Further reading

World Study on Physics and Detectors for a Linear Collider "<http://lcws.physics.yale.edu/lc/>".

2nd ECFA/DESY Study "<http://www.desy.de/conferences/ecfa-desy-lc98.html>".

Fermilab studies on a muon collider "[http://www.fnal.gov/projects/muon\\_collider/](http://www.fnal.gov/projects/muon_collider/)".

**David J Miller**, *University College London.*

**www.metrolab.com**

**Global range of magnetic measurement equipments**

**METROLAB**  
Instruments SA

- NMR
- ESR
- Hall effect
- Digital fluxmeter
- from mT to 50 Tesla
- Accuracy  $10^{-2}$  to  $10^{-8}$

tel : +41 (22) 884 33 11  
fax : +41 (22) 884 33 10  
E-mail: [contact@metrolab.ch](mailto:contact@metrolab.ch)  
110, ch. du Pont-du-Centenaire  
CH-1228 GENEVA Switzerland

**www.metrolab.com**

# Cryogenic Components



## Manufacturing Line

- Cryogenic Valves  
(Shut-off and Control Valves,  
Vacuum Jacketed and also for  
Cold Box Mounting)
- Special Valves for any Cryogenic  
Applications (Check-Valves, Pilot  
Cryogenic Valves, Relief Valves etc.)
- Bellows Sealed Valves  
(up to PN420)
- Cryogenic Transferlines and  
Couplings (Johnston and  
Multi-Coaxial Couplings)
- Space Cryogenic Components
- Custom made Cryogenic  
Components e. g.  
Cryostats and Ejectors

## Cryogenic Control Valve >

pneumatically operated, with intelligent electro-pneumatic positioner, travel feedback and limit switches, with vacuum weld-in flange for cold box mounting



**WEKA AG · Schürlistr. 8 · CH-8344 Bäretswil · Switzerland**  
**Phone ++41 01 939 29 59 · Fax ++41 01 939 29 63**  
**E-Mail: info@weka-ag.ch**

**Für USA und Kanada:** PROVAC LTD, POB 18411, Greensboro, North Carolina 27419  
 Phone (910) 282 6618, Fax (910) 288 3375, E-Mail: bollini@msn.com

**Für Japan:** NIPPON SANSO CORPORATION  
 PLANT & MACHINERY DIV., SPACE & CRYOGENIC EQUIPMENT DEPT.  
 6-2 Kojima-cho, Kawasaki-ku, Kawasaki-City, Kanagawa-Pref. 210, Japan  
 Phone 044 (288) 4063, Fax 044 (299) 4109  
 E-Mail: Kiyoshi\_Ishiwata@sanso.co.jp, WWW: www.sanso.co.jp

## Unravelling the Deepest Secrets of Nature

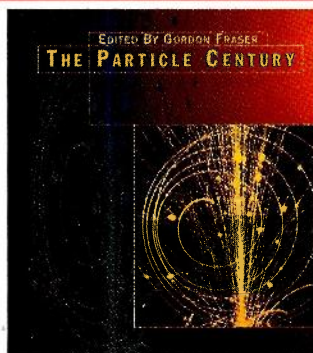

## The Particle Century

Edited by **Gordon Fraser**,  
CERN, Switzerland

**September 1998**

224 pages

12 page colour section

Hardcover

**£30.00/\$59.50**

ISBN 0 7503 0543 6

From the first attempts to split the atom to the discovery of the top quark, the 20th century has witnessed a revolution in basic physics. Probing successively smaller constituents of matter has also revealed the conditions present at the time of the Big Bang. In a series of essays by scientists who have been closely involved in this exciting research, *The Particle Century* describes the unprecedented advances in our understanding of the Universe.

Covering the major developments made during this, the particle century, including early accelerator physics, the rise of the standard model, the new comprehension in terms of the Big Bang, and extending to the cutting edge of current investigations, these essays add new insight to the continuing efforts to unravel the deepest secrets of Nature.

This unique collection of essays from a distinguished team will be enjoyed by the entire particle physics community, and by a wide audience beyond.

**Contributors:** Ahmed Ali, Guido Altarelli, John Ellis, Andy Fabian, Gordon Fraser, Jerome Friedman, Boris Kayser, Henry Kendall, John Krige, W O Lock, Yuval Ne'eman, Graham Ross, Carlo Rubbia, Nicholas Samios, David Saxon, Roy Schwitters, Quisar Shafi, M Shochet, Christine Sutton, M Veltman, Catherine Westfall, E J N Wilson, Sau Lan Wu.

**Special offer for readers of CERN Courier - SAVE 25%  
 £22.50/\$45.00 (Mail orders only).**

### Send your order to:

**UK/Outside UK** - Books Marketing, IOP Publishing Ltd., Dirac House, Temple Back, Bristol BS1 6BE, UK Tel: +44 (0) 117 929 7481 Fax: +44 (0) 117 929 4318

**USA/Canada** - Orders (in US\$) to IOP Publishing, c/o AIDC, 2 Wintersport Lane, PO Box 20, Williston, Vermont 05495-0020. Tel: 1-800 632 0880 (VT: 802 862 0095) Fax: 802 864 7626

Please send a cheque made payable to IOP Publishing Ltd, or use your credit card

Please send me (state amount) \_\_\_\_\_ copies of THE PARTICLE CENTURY

**P&P UK** Add £2.50 for the first book, then add .50p for each additional book

**ROW** Add £3.50 for the first book, then add .75p for each additional book

**USA** Add \$3.75 for the first book, then add \$1.00 for each additional book

I enclose a payment of £ \_\_\_\_\_

Please charge my credit card  MC/Access  Visa  American Express

Card Number

Expiry Date

Name \_\_\_\_\_

Address \_\_\_\_\_  
 \_\_\_\_\_  
 \_\_\_\_\_

Signature \_\_\_\_\_

**Institute of Physics PUBLISHING**

04/99

# KamLAND: neutrinos f

The Japanese Kamiokande underground detector played a leading role in the study of neutrinos produced via cosmic rays and also helped to pioneer the subject of neutrino astronomy. With Kamiokande now having given way to Superkamiokande, the Kamioka mine becomes the scene of a new neutrino project.

A new large neutrino detector is currently being constructed by an international collaboration that includes Hungary, Japan and the US in the underground site that used to be the home of the pioneering Kamiokande experiment. Called KamLAND (Kamioka Liquid scintillator Anti-Neutrino Detector), it will be the largest low-energy anti-neutrino detector ever built and will study a wide range of science, spanning particle physics, geophysics and astrophysics.

The principal goal will be to investigate the possibility of neutrino oscillations by studying the flux and energy spectra of neutrinos produced by Japanese commercial nuclear reactors. Approximately one-third of all Japanese electrical power (which is equivalent to 130 GW thermal power) is produced by nuclear reactors and KamLAND is centrally located on the main island of Honshu, therefore the experiment is exposed to a very large flux of low-energy anti-neutrinos, which are mainly produced at a distance of between 150 and 200 kilometres. The broad energy spectrum of antineutrinos emitted by the neutron-rich fission fragments of a reactor has a maximum at around 3.5 MeV.

## Oscillation behaviour

With two kinds of neutrinos, the oscillation probability depends on one mixing parameter and on the sine of  $\Delta m^2 L/E_\nu$ , where L is the "baseline" traversed by the neutrinos,  $E_\nu$  is the neutrino energy and  $\Delta m^2$  is the mass squared difference. Measurements would constrain  $\Delta m^2$  and the mixing parameter.

Since for a given baseline the oscillation probability depends on the neutrino energy, different neutrino energies will have different oscillation behaviour. Hence, in general, oscillations would distort and suppress the detected spectrum. With an expected (non-oscillating) rate of 700 antineutrinos detected per year, three years of data-taking would be a hundred-fold improvement over existing neutrino mass measurements.

More important is that the experiment's sensitivity covers one of

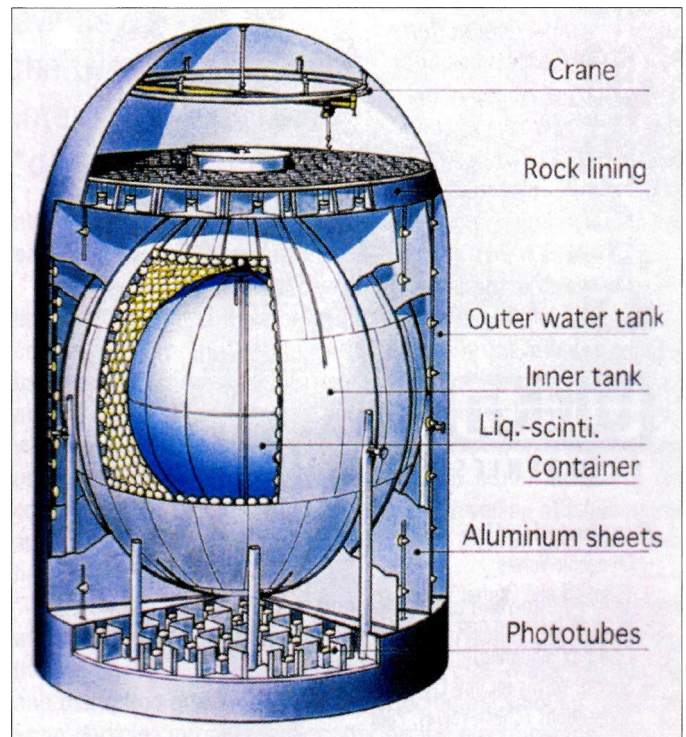

Second generation at Kamioka – an artist's bird's-eye view of the KamLAND neutrino detector.

the possible solutions of the "solar neutrino puzzle". While solar and atmospheric neutrinos have provided the first signals for neutrino oscillations, terrestrial experiments, with both source and detector well quantified, are required to investigate and understand such oscillations in detail.

While Minos in the US, K2K in Japan and a possible CERN-Gran Sasso beam are designed to investigate the mass region of interest for atmospheric neutrinos, KamLAND is the first attempt to study the solar neutrino puzzle "in the laboratory". This has a historical precedent in meson physics, where the first investigations were driven by cosmic-ray experiments using balloons or on high mountains, while subsequent discoveries and systematic study came via accelerators and bubble chambers.

KamLAND will, for the first time, also be able to detect antineutrinos from uranium and thorium beta decays inside the Earth. While the present experimental data on this topic are derived from sparse and shallow samplings, KamLAND will provide a global measurement. About half of the heat produced in our planet is believed to be produced by such decays, therefore this measurement will be of considerable geophysical interest.

In addition, comparisons with similar measurements from Borex-

# from heaven and Earth

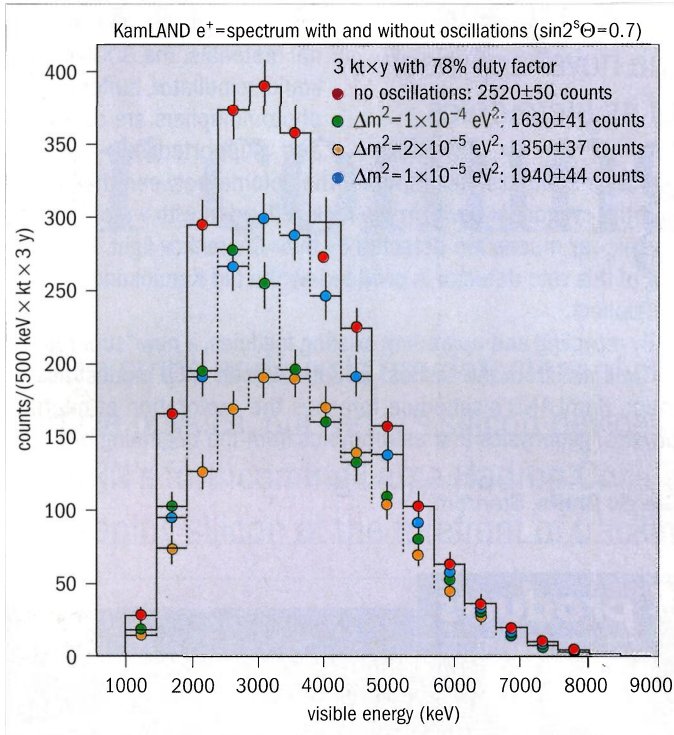

The effect of neutrino oscillations. Antineutrino spectra from neutron-rich reactor fission fragments, showing how different sets of neutrino oscillation parameters give different levels of distortion of the spectra.

ino (October 1998 p12) should make it possible to calculate the ratio of uranium to thorium in the crust and mantle of the Earth. This is because Borexino is surrounded by thick continental crust, while KamLAND is located at the edge of the Asian plate and, hence, over about half of its angular coverage it receives antineutrinos from beneath the Pacific Ocean.

## Recoil energy

A natural continuation of the KamLAND programme will include the direct observation of beryllium-7 and boron-8 solar neutrinos by detecting recoil energy in neutrino-electron scattering processes. While Borexino is particularly optimized for the study of beryllium-7 solar neutrinos, the larger mass of KamLAND opens up the low-energy measurement of the rarer boron-8 neutrinos. (The high-energy component of such neutrinos will be covered by the SuperKamiokande and Sudbury (SNO) water-Cherenkov detectors.)

The direct detection of solar neutrinos involves single ionization events (as opposed to double in the case of reactor and terrestrial antineutrinos), thus the quality of these measurements will depend

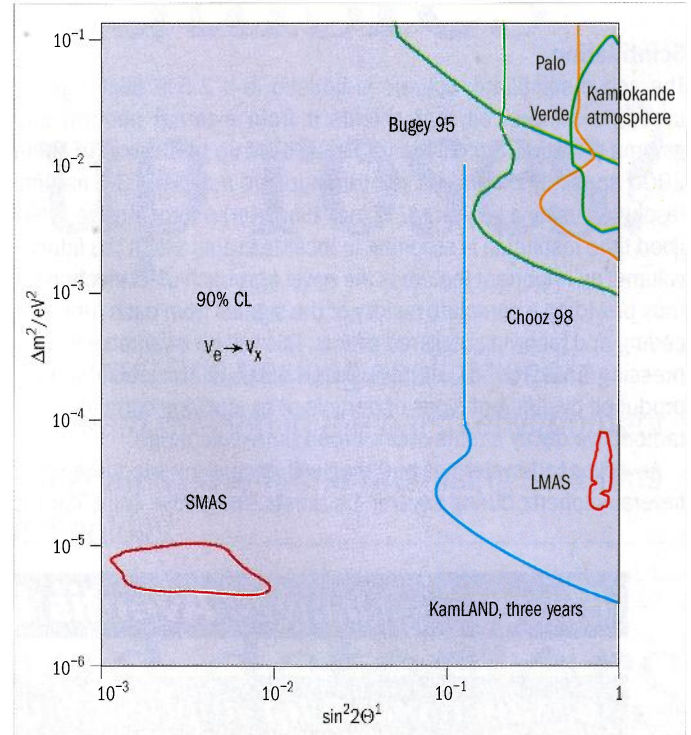

KamLAND will improve existing neutrino mass measurements by two orders of magnitude.

on the extent to which the radioactive contamination (and hence the background) can be controlled. Here the kiloton mass of the detector is a major asset, allowing the active scintillator volume to be separated from the external components by a very thick layer of inert shielding oil.

Should the background be higher than expected, an additional layer of scintillator will be used as shielding, with a software cut on the event position, while retaining a very large fiducial volume. Simulations show that the KamLAND background will be dominated by the internal radioactivity of the scintillator, and by the radon produced mainly in the photomultiplier glass and carried to the centre of the detector by convection.

The first phase of running will show conclusively whether more effort is needed for precise observations of the solar neutrino fluxes to be made. Such a staged approach minimizes expense and effort in the notoriously tricky field of detector background. Searches for supernova neutrinos, solar antineutrinos and, possibly, neutrinoless double beta decay will complete the physics programme.

The heart of KamLAND will be a spherical volume containing a kiloton of very-high-purity liquid scintillator. Unlike water-Cherenkov detectors that can only detect relatively high-energy particles, Kam-

LAND's scintillator has enough sensitivity to detect fractions of a mega electron volt, with the possibility of background-free low-energy electron-type antineutrino detection. This would be achieved by observing both the positron and the neutron produced by the inverse beta decay capture of antineutrinos by protons. Fake events resulting from natural radioactivity and cosmic-ray backgrounds are reduced by different layers of shielding, the careful selection of construction materials and event signature.

### Scintillation

The active scintillator volume is housed in a 2.5 m thick layer of ultrapure mineral oil that shields it from external neutron and gamma radiation. Scintillation light is picked up by an array of about 2000 specially developed photomultipliers achieving 3.5 ns time resolution using a very large (17 inch diameter) photocathode. While good time resolution is essential to localize events within the fiducial volume, an important feature is the novel approach of its electronics, thus providing a complete history of the signals from each tube preceding and following triggered events. This will be invaluable in suppressing backgrounds, either using the scintillator pulse shapes produced by different types of particle or by studying correlations in radioactive decay chains over a broad timescale range.

An advanced system of buffering will ensure no deadtime up to several kilohertz during several 1 s bursts. The active scintillator is

**While good time resolution is essential to localize events within the fiducial volume, an important feature is the novel approach of its electronics.**

diameter stainless-steel sphere. The volume between the sphere and the cylindrical cavity in the rock is flooded with water in which cosmic-ray muons are detected by their Cherenkov light. The read-out of this veto detector is provided by the old Kamiokande photomultipliers.

By recycling and upgrading existing facilities, a new "superdetector" will rise from the "ashes" of Kamiokande for a modest investment. KamLAND's schedule foresees the exploration of neutrino physics, geophysics and astrophysics from the beginning of 2001.

**Giorgio Gratta, Stanford.**

## Everything changes: Aventis HTS products

*for superconductor applications*

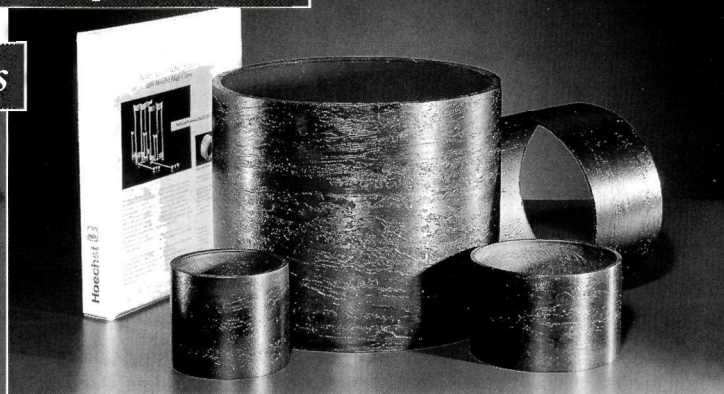

You have known us as Hoechst Corporate Research & Technology. As a result of the changes in the Hoechst group, we have a new name and new appearance: our new, own identity: Aventis

HTS current leads based on MCP BSCCO rods and tubes from Aventis are the first application of ceramic superconductors in electrical power engineering with currents up to 10.000 A.

A reduction of the heat load to the 4K level by more than a factor of 10 was achieved. This results in a significant reduction of the refrigeration costs and allows new innovative cooling concepts.

Parts of up to 400 mm in length or diameter can also be used in applications in the field of magnetic shielding, current limiters or others.

If you are interested in further information, please contact:

Aventis Research & Technologies GmbH & Co KG

Dr. Joachim Bock  
High Temperature Superconductors  
Chemiepark Knapsack  
D-50351 Huerth Germany  
Tel: (+49) 2233 486658  
Fax: (+49) 2233 486847  
Email: [bock@msmiuk.hoechst.com](mailto:bock@msmiuk.hoechst.com)

# Aventis

Research & Technologies

A member of the  
Hoechst Group



# Silicon detectors: pushing up daisies or coming up roses?

Silicon strips and pixels are detectors of choice for front-line tracking applications in particle physics, but today's silicon devices will be hard pushed in the harsh environment of CERN's forthcoming Large Hadron Collider. Two groups have found promising solutions for keeping silicon at the forefront of tracking technology.

## Raising the dead detectors

The RD39 collaboration at CERN investigates heavily irradiated silicon detectors operated at cryogenic temperatures. Its results show that, below 100 K, such detectors can be brought back to life. This phenomenon has been dubbed the Lazarus effect after the Biblical character who was raised from the dead by Jesus after being entombed for four days.

Silicon detectors placed as close as possible to particle beams measure the trajectories of particles as they emerge from collisions. At CERN's flagship accelerator, the Large Electron-Positron collider (LEP), silicon detectors can expect to be traversed by around ten thousand million particles per square centimetre over their lifetime.

However, at CERN's next big accelerator, the Large Hadron Collider (LHC), this number will rise to a mammoth thousand million million passing particles per square centimetre.

Silicon detectors used as they have been in the past would not be able to cope with this enormous integrated particle flux. After prolonged exposure to passing particles, defects begin to appear in the silicon lattice as atoms become displaced, leaving lattice vacancies and atoms at interstitial sites. These have the effect of temporarily trapping the electrons and holes (holes are missing electron states that behave like positively charged particles), which are created when particles pass through the detector. Since it is these electrons and holes that announce the passage of a particle, lattice defects destroy the signal.

Substantial progress has been made in designing radiation-hard detectors by paying special attention to the design of detectors and improving on silicon's properties. Now, serendipity seems to have brought another new solution. Using experience gained in searches for cold dark matter particles, where small signals demand the sensitivity of cryogenic detectors, a group of physicists at Bern decided to see what would happen to radiation-damaged silicon detectors when they were cooled to cryogenic temperatures. The researchers

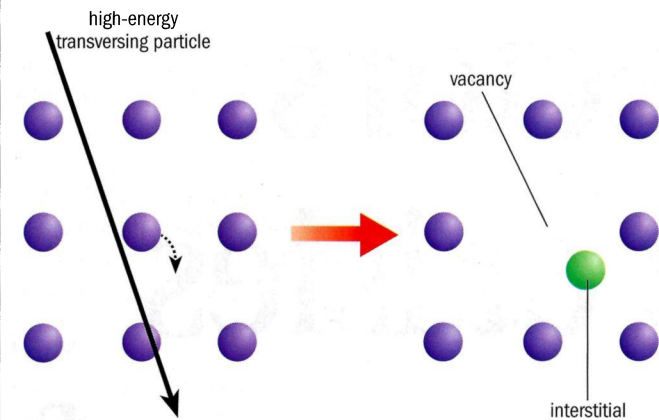

Above left: when a high-energy particle traverses a silicon detector, lattice defects are produced. These take the form of lattice vacancies and atoms at interstitial sites. They move around and combine with bulk impurities to create energy levels in the normally “forbidden” bandgap.

found that, below 100 K, dead detectors come back to life.

The explanation for this phenomenon appears to be that, at such low temperatures, the electrons and holes that are normally present in silicon detectors, which form a constant so-called “leakage” current, are themselves trapped by the radiation-induced defects. Moreover, the rate at which these electrons and holes become untrapped is greatly reduced as a result of the reduced thermal energy. Consequently, a consistent and large fraction of radiation-induced defects remains filled. This means that electrons and holes that are released by passing particles cannot be trapped and the signal is not lost.

However, the story is not as simple as this. Closer investigation reveals that, for extreme radiation doses, exceeding those expected after 10 years of LHC operation, the signal is only partially recovered. Understanding this behaviour requires further study.

Another advantage of low-temperature operation is the possibility of using simplified detector designs and low-purity material, thus opening the way to a substantial reduction in cost.

## The Lazarus effect

This is not the first time that low temperatures have been used to improve the performance of particle detectors. In fact, the Lazarus effect is very similar to a technique that has been known since 1981 to physicists using charge-coupled device (CCD) detectors.

CCDs were first tried in a test beam at CERN by the NA32 collaboration, which went on to use them successfully in its experiment. Similar detectors have been used for Stanford’s SLD vertex detector and its upgrade. These detectors were run at a relatively tropical 220 K to reduce the leakage current and to freeze out radiation-induced damage in the detector.

CERN’s RD39 collaboration plans to study the Lazarus effect in depth. The first step came in August 1998 when two silicon detectors with full read-out from the Delphi experiment at LEP were put into a test beam along with prototype detectors for the forthcoming COMPASS experiment. Members of the LHCb collaboration were also involved, because close-to-the-beam tracking is a vital feature of the group’s planned experiment.

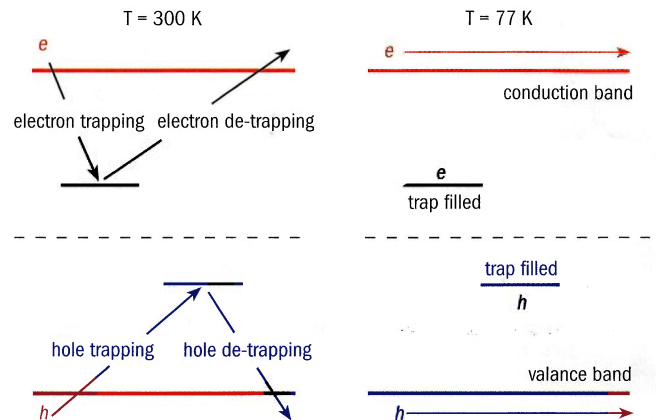

Above right: at room temperature these radiation damage-induced energy levels trap electrons and holes resulting from ionization. These are then emitted back to the conduction or valence band in a time period that is typically longer than the read-out time for the detector. Consequently the signal is degraded. At cryogenic temperatures, however, once a carrier is trapped it remains trapped owing to the very low thermal energy, and a large fraction of “traps” become filled. This prevents the trapping of electrons and holes generated by particles traversing the detector, therefore no signal is lost. This is known as the Lazarus effect.

One of the Delphi detectors had previously been irradiated with a comparable particle dose to that expected after a few years of LHC operation; the other was undamaged. The test beam demonstrated not only that the signal recovers at low temperatures, but also that the positional accuracy of silicon was not impaired, the two silicon detectors producing compatible results. Delphi’s standard read-out electronics also worked well at low temperatures.

A second test in November placed a healthy 3×3 pad array of silicon detectors in the beam line of the NA50 experiment, fully intercepting the highest intensity lead-ion beam at CERN. Permanently operated at 77 K, the 1.5 square millimetre pad centred on the beam performed well, even after being traversed by some ten thousand million lead ions. The pulses from each incident ion and the total ionization current from the detector were continuously monitored during and between beam pulses, with the results clearly showing that the detector survived this extreme environment without any noticeable change in performance.

These test beam results suggest that conventional silicon detectors operated at liquid nitrogen temperature could still remain the detectors of choice for the next generation of particle physics experiments. RD39 plans a series of proof-of-principle experiments to confirm its early findings and to demonstrate the feasibility of a low-cost cryogenic silicon tracker. The collaboration will also optimize a new high-intensity radiation-hard beam monitor based on the Lazarus effect. The results will be closely followed by the collaborations preparing for physics at the LHC.

## Further reading

V G Palmieri *et al.* (1998) Evidence for charge collection efficiency recovery in heavily irradiated silicon detectors operated at cryogenic temperatures *Nucl. Instr. Meth. Phys. Res. A* **413** 475–478.

# Perfect rose

The Rose collaboration (RD48: R&D on silicon for future experiments) at CERN has tackled the same problem as RD39, from a different angle but with similar success. Its approach is “defect engineering”: the careful control of impurities – particularly carbon and oxygen – in the silicon lattice.

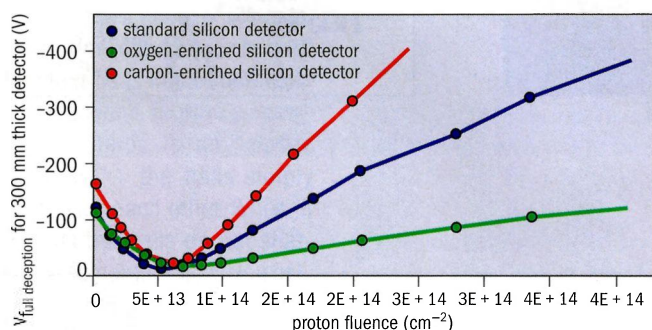

The Rose collaboration has shown that high concentrations of oxygen in a silicon detector dramatically improve radiation hardness (green curve) compared with standard silicon (blue curve). Carbon in the lattice (red curve) actually diminishes the detector's performance.

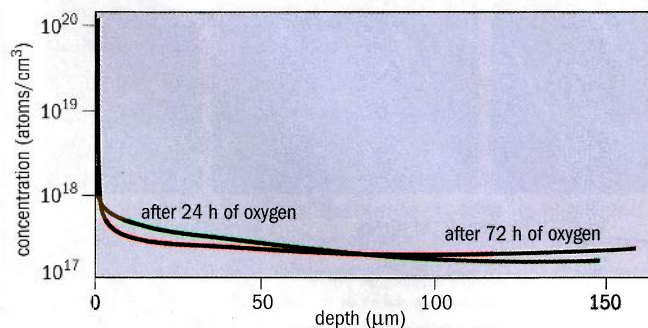

A technique developed by the Rose collaboration shows that oxygen can be diffused into standard silicon wafers.

Just as steel embedded in concrete has a dramatic effect on the properties of the finished product, so impurities in silicon can change the behaviour of silicon detectors. In 1996 the Rose collaboration set out to test the hypothesis that carbon and oxygen impurities, in particular, would improve the radiation tolerance of silicon, allowing it to be used for detectors in the LHC.

Oxygen and carbon were chosen because, according to models of radiation damage, oxygen should “capture” vacancies in the silicon lattice and carbon should capture silicon interstitials. Also, oxygen and carbon are always present to some extent in detector-grade silicon, making them prime candidates for further studies. This capturing effect would then render the lattice defects inactive, just as extreme cold does in the Lazarus effect. Unlike the Lazarus effect, however, silicon detectors made radiation-hard through defect engineering could be operated with only moderate cooling.

More than a dozen samples of silicon doped to various degrees with carbon and oxygen were studied while undergoing irradiation corresponding to the full lifetime of a detector in the LHC. While not entirely agreeing with model predictions, the results were encouraging. Carbon in the silicon lattice diminishes performance, while oxygen improves radiation hardness to a greater degree than foreseen.

The strength of the effect with oxygen was not the only unexpected outcome. As part of the Rose programme, samples were irradiated with different kinds of particle: neutrons, protons and pions. At the LHC, the radiation that traverses the detectors closest to the beam pipe is expected to consist mainly of pions, but, further away from the initial collision, neutrons will become more important.

The results show a performance improvement of a factor of three for strongly interacting charged particles in oxygenated detectors, compared with those of standard silicon detectors. Curiously, no improvement is seen for detectors irradiated by neutrons. However, because in most situations charged particles make up a substantial fraction of the radiation environment, the improvement in performance for charged particles is welcome. Moreover, a simple method has been found to diffuse oxygen into any silicon wafer prior to, or during, processing, and this is being transferred to detector manufacturers. Experiments such as DESY's HERA-B, which replaces its silicon detectors each year, should be among the first to benefit.

Detectors are not the only place where solutions to such problems are needed. In the electronics industry, limitations with ion-implantation techniques are holding up progress in transistor miniaturization. In response to this problem, the EU supports the European Network in Defect Engineering of Advanced Semiconductor Devices (ENDEASD), which is linked to the Rose collaboration. ENDEASD combines a range of academic institutions and semiconductor manufacturers, bringing much extra expertise and knowledge to the complicated subject of radiation effects.

Given the success of both the Lazarus and Rose collaborations, the obvious question to ask is whether an even higher performance could be achieved by combining the two techniques. This is high on the agenda for both collaborations and will be investigated this year. LHC experiments are already preparing to put out invitations to tender for their tracking detectors, so for Lazarus and Rose the timescale to produce working detectors is tight. However, with the progress made so far, even at temperatures below 100 K, both collaborations are confident that the future for silicon looks rosy.

## Further reading

Second RD48 (ROSE) Status Report CERN/LHCC 98-39 LEB Status Report/RD48 21 October 1998.

ENDEASD Web site “<http://www.brunel.ac.uk/research/ENDEASD>”.

**James Gillies**, CERN.

# UNE HAUTE IDÉE DE L'ENTREPRISE

À 10 minutes de l'aéroport international de Genève, au carrefour des réseaux autoroutiers F/CH/D/I, près de deux gares TGV, à proximité du prestigieux CERN.

propose sur 40 hectares :  
des parcelles de terrains viabilisées (achat ou location)  
des bureaux et des bâtiments mixtes  
une pépinière d'entreprises  
des services spécifiques d'assistance aux entreprises pour une implantation régionale et pour des relations avec le CERN  
un Bureau de Rapprochement des Entreprises agréé par l'UE.

## LE TECHNOPARC - PAYS DE GEX -

A Ten minutes' drive to Geneva International Airport, at the crossroads of the F/CH/D/I motorways, close to two TGV railway stations, right next to the prestigious CERN.

proposes 100 acres (40 ha) of equipped site with :  
pieces of land (purchasing or renting)  
offices spaces  
activity buildings  
incubator  
Business Corporation  
Center agreed by EU.

**CONTACT :**  
**COMMUNAUTÉ DE COMMUNES  
DU PAYS DE GEX**  
Technoparc - Pays de Gex -  
F-01630 Saint-Genis-Pouilly  
Tél. 04 50 42 65 00 - Fax 04 50 42 65 01  
E-mail : bregex@leman.com  
internet : <http://www.leman.com/~bregex>

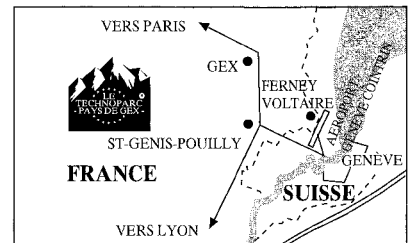

### Model 218

## Setting the Standard in Temperature Monitoring

www.lakeshore.com

**8 Channels**

- All sensors read twice each second
- Individual current excitation
- Eight displays of temperature, volts or ohms
- Platinum RTDs, Silicon Diodes and NTC Resistive sensors

Lake Shore Cryotronics, Inc. • 575 McCorkle Blvd.  
Westerville, OH 43082 • Phone: (614) 891-2244 • Fax: (614) 818-1600

sales@lakeshore.com

## BIMETALLIC TRANSITION JUNCTIONS

**THE T+C / CEA KNOW-HOW :**  
for the assembly of different metals under stringent reliability

**VARIOUS APPLICATIONS**

Class 1	• Normal Cryogenics
Class 2	• Advanced Cryogenics
Class 3	• Space, nuclear, chemicals

**STANDARD TRANSITION ON STOCK  
QUALITY ASSURANCE**

**CALL FOR DETAILS**  
V. MOULIN  
Phone: (33) 472.02.68.00  
Fax (33) 472.02.68.01  
E-Mail Info @Thevenet.Clerjounie.Fr

# T+C

**THEVENET + CLERJOUNIE**  
22, avenue Franklin Roosevelt - 69517 VAULX-EN-VELIN (France)

# Probing the pomeron

What ultimately controls the way particles interact? Different particles appear to interact at high energies in similar ways through a mechanism known as pomeron exchange. Sandy Donnachie explains what we know about the pomeron.

Particle physics experiments ultimately depend on the way pairs of particles scatter off each other. A simple example of scattering is a game of billiards, in which the cue ball scatters off the other balls in carefully chosen directions. In physics language, billiards is an “elastic scattering” – the balls simply bounce off each other. While in billiards the balls do not shatter, in elementary particle scattering the objective is usually to create havoc, the balls knocking bits off each other or even disintegrating totally, creating new balls in a complicated game of snooker that is played under the rules of relativity and quantum mechanics.

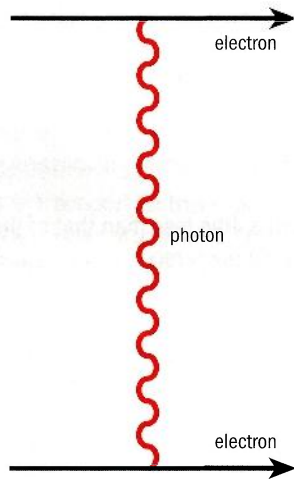

Fig. 1: The exchange of an invisible light quantum (photon) controls the electromagnetic interaction between two electrons.

The interaction of ordinary billiard balls can be understood by their elasticity. After an initial compression as they collide, two balls subsequently spring back into shape and recoil away. For the more complex process of particle interactions, physicists understand the interaction via invisible particles transferring momentum from one visible particle to another as they pass each other. Such an “exchange process” is illustrated in figure 1, which shows the electromagnetic interaction between two electrons mediated by the exchange of an invisible light quantum or “photon”.

For the high-energy scattering of particles that feel the strong force, such as protons, the same physical concept applies, but now the exchange is made by whole families of related particles. One such is the rho family, named after its lightest member, the spin-1 rho meson, which comprises the rho and its cousin spin-3, spin-5,.... recurrences at higher mass.

Regge theory (after the Italian physicist Tullio Regge) gives the collective effect of the exchange of all of the members of such a family in terms of a Regge trajectory  $\alpha(t)$ , which is described mathematically as a function of the invariant momentum transfer,  $t$ . The

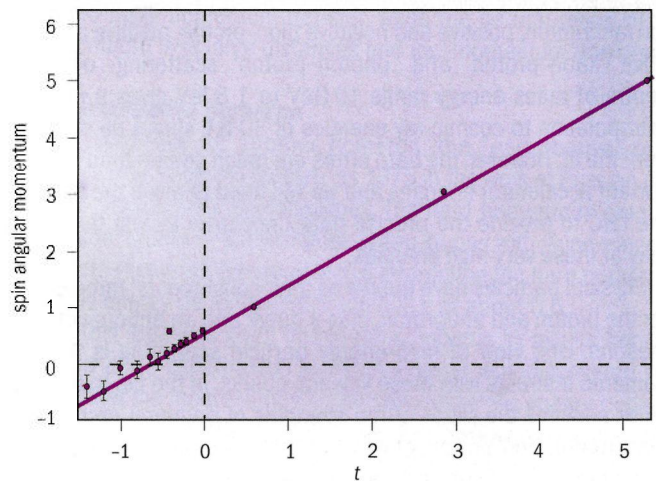

Fig. 2: The Regge trajectory simulates the collective effect of exchanging all members of a family of particles. When  $t$  is negative it is the square of the momentum transferred in the exchange. Positive  $t$  is the squared mass of the physical particles of spin 1, 3, 5,...

rho trajectory is shown in figure 2 for the “time-like” region of positive  $t$  corresponding to the real physical particles of spin-1, spin-3, spin-5, etc. and in the “space-like” region of negative  $t$  relevant for the exchange in a scattering process. The trajectory is well described by a straight line:  $\alpha(t) = \alpha_0 + \alpha't = 0.55 + 0.86t$ . This is an experimental result: it cannot be predicted by Regge theory. It turns out that the trajectories of all of the dominant meson-exchange families lie close to this line – they are almost degenerate.

## Regge theory

Regge theory tells us that the energy dependence of the sum of everything that happens – the “total cross-section” – is dependent on the value of the trajectory at  $t=0$ . Specifically, it is given by the square of the collision energy,  $s$ , raised to the power  $\alpha_0 - 1$ . As all of the meson trajectories are nearly degenerate and have  $\alpha_0 = 0.55$ , the energy dependence is  $s^{-0.45}$ , roughly as the inverse of the square root of  $s$ , so the prediction of Regge theory for meson exchange is that the cross-section should decrease with increasing energy and do so at a well defined rate.

While such behaviour is indeed seen at collision energies below about 15 GeV, at higher energies the total cross-section at first flattens out and then begins to rise slowly, an effect first hinted at in cosmic-ray data, demonstrated unambiguously for the first time at the CERN ISR Intersecting Storage Rings and the rising trend confirmed at the CERN's proton-antiproton collider and at Fermilab's Tevatron. The cross-section for proton-proton and proton-antiproton scattering is shown in figure 3. The simplest assumption to make is that this rising cross-section is due to the exchange of another Regge trajectory and so also gives a simple power of  $s$ . To produce a rising cross-section it must be such that  $a_0 = 1 + \epsilon$  with  $\epsilon$  positive. This is the phenomenological or "soft" pomeron, named after the Russian physicist Igor Pomeranchuk.

The parameter  $\epsilon$  is universal, independent of the particles being scattered. Fitting the total cross-sections for proton-proton, proton-antiproton, positive and negative pion-proton, positive and negative kaon-proton and photon-proton scattering over the centre-of-mass energy range 10 GeV to 1.8 TeV gives  $\epsilon = 0.095$ . Extrapolation to cosmic-ray energies of 30 TeV shows no deviation from the fit. However, the data errors are much greater than those at current accelerator energies and we will need to await the arrival of the LHC to provide the precise data necessary to test the theory fully at these very high energies.

Physical particles have quarks as their constituents: three quarks for the proton and antiproton, plus a quark and an antiquark for the mesons. One view of high-energy particle scattering is that the pomeron interacts with these valence quarks. In the fits to the total cross-sections the ratios of the strengths of pomeron exchange in pion-proton and proton-proton or proton-antiproton scattering is almost exactly 2/3. This can be taken as evidence that the pomeron does indeed couple to single valence quarks in a hadron – the "additive quark rule".

An alternative viewpoint is that the pomeron interacts both with the valence quarks and with the gluons that bind the quarks together to form the physical particles, and the cross-section ratios simply reflect the different sizes of these particles. This issue is still unresolved.

### Unitarity

Although the data are well described by single pomeron exchange, an ever-increasing cross-section will ultimately violate what physicists call unitarity – the probability of something happening becomes greater than 100% – clearly impossible. This is avoided by the exchange of more pomerons as the energy increases. These contribute with alternating signs and with increasing strength, and ultimately damp down the energy dependence.

A fundamental theorem due to the French physicist Marcel Froissart says that the total cross-section cannot increase faster than  $\log^2 s$  and multiple pomeron exchanges can ensure this. The Froissart bound is asymptotic and is not relevant at present energies. At present energies the effect of multiple pomeron exchanges is rather small. Even at Fermilab Tevatron collision energies of 1.8 TeV, they contribute only about 10% to the total cross-section and less at lower energies. The effect of adding a small two-pomeron exchange contribution is that the experimental result for  $\epsilon$  is an effective value

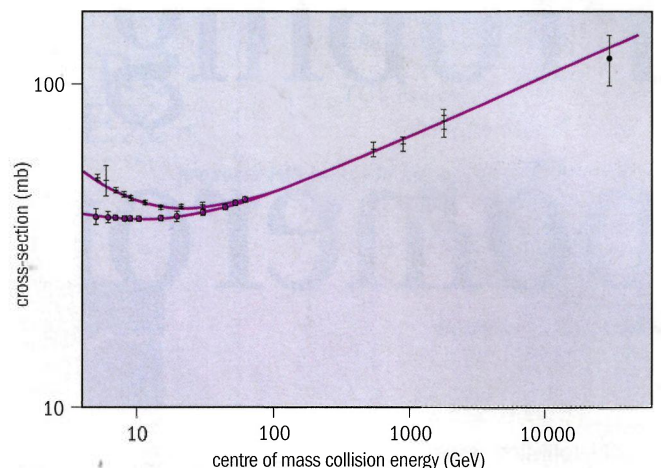

Fig. 3: Energy behaviour of proton-proton and proton-antiproton (upper curve) scattering. If the increase is presumed to be due to the exchange of a "pomeron", then physicists have to discover what the pomeron is.

and a little less than that of the single pomeron.

Total cross-sections only provide information on the pomeron trajectory at  $t=0$ . They tell us nothing about the  $t$ -dependence of the trajectory. This can only be obtained from studying the angular distribution of the protons – the differential cross-section – when they scatter off each other.

It appears that the pomeron trajectory is linear, just like the meson trajectories, but with different numbers in the formula:  $\alpha(t) = 1 + \epsilon_0 + \alpha' t$ . The data indicate that the slope parameter  $\alpha' = 0.25$ , a number first obtained in 1973 from an analysis of the ISR data.

At small values of  $t$  the differential cross-section can be represented by an exponential:  $e^{-bt}$ . The slope parameter,  $b$ , is energy-dependent, and Regge theory can predict this energy dependence in terms of the trajectory. The effect is that  $b$  increases as the energy increases, so that the forward peak of the differential cross-section becomes steeper, a phenomenon that is known as "shrinkage". For  $\alpha' = 0.25$  the predicted change in  $b$  from ISR to Tevatron energies is  $3.5 \text{ GeV}^{-2}$ . This is in excellent agreement with the data and is something of a triumph for Regge theory.

The pomeron provides a simple, economical and accurate

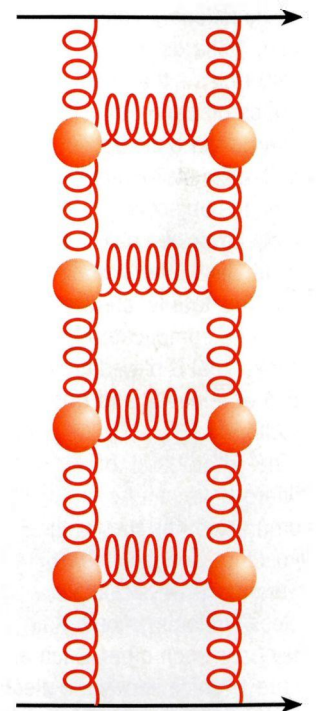

Fig. 4: Some pomeron effects could be due to the exchange of a gluon "ladder".

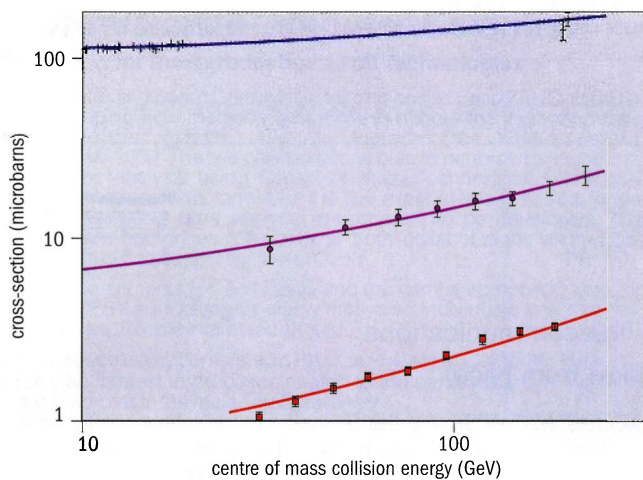

Fig. 5: Unsolved mystery: experiments at DESY's HERA electron-proton collider show that the greater the momentum transfer, the greater the energy dependence of the scattering. Momentum transfer increases from the top to the bottom. There is no consensus on the real reason for this dramatic change and several models fit the data rather well. The curves show Sandy Donnachie and Peter Landshoff's proposal for two-pomeron exchange.

description of high-energy scattering, but what is it? When we introduced the meson trajectories, we linked them to physical particles for positive  $t$  values and then extrapolated to the scattering region where  $t$  is negative. Is the pomeron trajectory similarly linked to physical particles? Can one not simply reverse the process for the pomeron and extrapolate from the scattering region to the physical region? The extrapolation is a longer one, but assuming that the linear trajectory is valid for all values of  $t$ , it predicts a physical particle of spin-2 at a mass of about 2 GeV. This cannot be one of the known mesons: they are already members of the meson trajectories and it has the wrong mass and spin to be associated with them. This means that this "pomeron particle", if it exists, must be something other than a quark-antiquark state. The favourite interpretation is that it is a "glueball", composed of two gluons.

### Quantum chromodynamics

It is natural to try to relate the pomeron to our understanding of quantum chromodynamics, the field theory of quarks and gluons, and to describe it in terms of gluon exchange. The simplest picture, that the principal effect is just the exchange of two gluons, was proposed independently in 1975 by American physicist Francis Low and Israeli physicist Shmuel Nussinov.

Subsequent development of this idea, principally at Cambridge and Heidelberg, has shown that it is compatible with all soft-pomeron phenomenology except for one aspect: two-gluon exchange gives a constant, not a rising, cross-section. The exchanged gluons must interact with each other to produce an increase.

How can one measure the quark and gluon content of the pomeron? In 1985, Swedish physicist Gunnar Ingelman and Amer-

ican physicist Peter Schlein suggested that the content of the pomeron could be established in ways analogous to those used to finding the quark-gluon content of the proton by probing it in high-momentum transfer reactions.

The first results for the pomeron were obtained by the UA8 experiment at the CERN proton-antiproton collider, establishing the validity of the concept and technique, but this experiment could not distinguish between quarks and gluons. This has been achieved by the H1 and ZEUS experiments at the HERA electron-proton collider at DESY. A clear separation can be made and gluons are found to constitute about 90% of the pomeron.

However, another question immediately arises: are the UA8 and HERA experiments probing the soft pomeron or something entirely different? To study quark-gluon content requires small distances and high-momentum transfer, while the natural realm of the soft pomeron is at large distances and low-momentum transfer.

### Perturbative pomeron

A candidate for another pomeron, the "perturbative" or "hard" pomeron, emerged as early as 1975 in the work of Russian physicist Lev Lipatov and his colleagues. The hard pomeron is essentially a gluon "ladder" - the exchange of two gluons with gluon rungs joining them (figure 4). Because of this interaction the hard pomeron does give energy dependence, predicting  $\epsilon$  of about 0.5.

This idea was given tremendous impetus by results from the H1 and ZEUS experiments at HERA when it was discovered that the greater the momentum transfer, the greater the energy-dependence of the cross-section. The change from the low-momentum transfer, long-range interaction to the large-momentum transfer, short-range interaction is shown in figure 5. There is at present no consensus on the real reason for this dramatic change, and there are several models on the market that fit the data rather well. British physicists Sandy Donnachie and Peter Landshoff have taken the two-pomeron scenario seriously, and the curves in figure 5 are the result of their fit to the data.

The phenomenological pomeron has enjoyed remarkable success in describing a range of data, and that part of the story will not alter. However, the existence of the hard pomeron is still speculative, and its nature and theoretical explanation remain questions for the future. Data on photon-photon interactions at high energies from the LEP experiments will provide a new and powerful probe of this concept.

It is already clear from the measurements of the real photon-photon total cross-section by the L3 and OPAL experiments at CERN's LEP electron-positron collider that more than the soft pomeron is required. Proton-proton data from Brookhaven's RHIC collider, which is scheduled to come into operation this year, will complement existing proton-antiproton data and test our implicit assumption that there is no difference between proton-proton and proton-antiproton scattering at high energies. In the longer term, CERN's LHC will provide the long lever arm necessary to investigate the effect of multiple pomeron exchange and possibly to seek the presence, at some level, of the hard pomeron in purely soft interactions.

**Sandy Donnachie, Manchester.**

# RECRUITMENT

For advertising enquiries contact *CERN Courier* recruitment/classified, IOP Publishing Ltd, Dirac House, Temple Back, Bristol BS1 6BE, UK.  
Tel: +44 (0)117 930 1026 Fax +44 (0)117 930 1178

**Rates** per single column cm: Mono £30, Single colour £34, Full colour £36. Please contact us for more information on publication dates and deadlines.



ÉCOLE POLYTECHNIQUE  
FÉDÉRALE DE LAUSANNE



## Education and research in Telecommunications Sophia-Antipolis (10 km from Nice)

Founded in 1991 by the French Institute of Telecommunications (ENST-TELECOM PARIS), and the Swiss Federal Institute of Technology Lausanne (EPFL), Eurécom is a university-level education and research institute in Telecommunications: 60 academic staff and 100 students (130 in year 2000). The board includes important organisations and research centres and major companies involved in communication and information technology, integrated in the "Telecom Valley" concept. In 1994, Eurécom received from IEEE the Major Educational Innovation Award. The fast evolution of the telecommunications science demands a unique adaptive curriculum. Eurécom is proud to have its alumni already present in the most successful Universities and companies worldwide. It is now a far reaching example of tomorrow's higher education institutes.

The board of Eurécom seeks a:

## General Director

### Main Tasks:

- Manage and develop a scientific and pedagogical policy and planning
- Assure and develop the promotion and acceptance with the academic and industrial partners
- Manage a research and higher education institute of 75 staff (academic and administrative).

Please send your CV to Nicole Haefliger  
K/F Selection  
Limmatpark – 8957 Spreitenbach – Switzerland

### Qualifications:

- Personality with a professional vision, solid, reliable, entrepreneur and talented communicator
- Senior academic or research career in a related field
- Experience in the management of research teams and projects
- French and English

For increased speed, you may fax ++41 56 401 65 07  
or e-mail to us at: [nicole.haefliger@kornferry.com](mailto:nicole.haefliger@kornferry.com)  
Your application will be treated confidentially.

**K/F SELECTION – A DIVISION OF KORN/FERRY INTERNATIONAL**



UNIVERSITY OF  
OXFORD

Department of Physics

### Postdoctoral Fellowship in Astroparticle Physics

RS1A - Starting Salary £17,570 p.a.

Applications are invited for the above PPARC funded fixed-term post tenable for two years from 1st October 1999. The successful candidate will be expected to carry out research in astroparticle physics under the direction of Professor G G Ross and Dr S Sarkar.

The research areas of particular interest for this position include cosmological phase transitions, inflation and large-scale structure, baryogenesis, neutrino astrophysics and cosmology, and very high energy cosmic rays.

Further particulars may be obtained from Mrs G Dancey (e-mail: [g.dancey1@physics.ox.ac.uk](mailto:g.dancey1@physics.ox.ac.uk)). Applicants should submit a Curriculum Vitae, a list of publications and a brief research plan, and ask three referees to write directly to the Administrator, Department of Physics, Clarendon Laboratory, Parks Road, Oxford OX1 3PU by 15th March 1999.

The University is an Equal Opportunities Employer.

## Creighton University



Applications are invited for an immediate research opening in relativistic heavy ion physics. The group is working on the hardware controls system (using EPICS and CDEV) and test data analysis for the STAR experiment.

The successful candidate will have an interest in working with undergraduate and Masters students. He/she should plan to be based at Brookhaven National Laboratory.

Further information: **Michael Cherney Tel: 402-280-3039**  
**Fax: 402-280-2140 Email: [mcherney@creighton.edu](mailto:mcherney@creighton.edu).**

Applicants should outline their experience with electronic interfaces and controls software. **Physics Department Creighton University**  
**2500 California Plaza Omaha NE 68178**

*Creighton University is an Equal Opportunity/Affirmative Action Employer.*





DESY is a physics research laboratory with 1.400 employees and more than 3.000 guest scientists from Germany and abroad. The scientific programme includes research in particle physics and synchrotron radiation.

DESY invites applications for the position of an

## Physicist/Computer Scientist for the Introduction of OO Technologies

The two Colliding Beam Detector Collaborations, H1 and ZEUS, at DESY are developing new methods and tools to handle the increased data volume expected from the Luminosity Upgrade of the HERA ep collider after the year 2000. The two collaborations plan to perform major parts of the physics analysis using Object-Oriented Technologies. In a pilot project a common data format for the two experiments is to be defined and the necessary data analysis environment to be developed. The project team comprises members of both collaborations and of the central computing support group at DESY.

The two experiments H1 and ZEUS and the central computing support group at DESY are looking for highly motivated individuals to participate in this project. People interested should

- have successfully completed a Ph.D. in Physics or Computer Science,
- have an interest in problems related to the handling and analysis of data samples in the multi-TeraByte range,
- have experience or be interested in Object-Oriented Programming Technologies,
- be willing to work closely together in a team consisting of Physicists and Computer Scientists.

The appointment will be at DESY in Hamburg and be initially limited to 3 years. Conditions are those of the German "Bundesangestelltentarif (BAT)".

Interested candidates, under 32 year of age, should submit an application consisting of a curriculum vitae, copies of university degrees and a publication list, and should arrange to have three letters of recommendation sent directly to:

**DESY, Personalabteilung, Notkestraße 85, D-22607 Hamburg, by April 30th, 1999. Code-No. 16/99**

Handicapped applicants will be given preference to others with the same qualifications. Women are especially encouraged to apply.

## DIRECTOR

### LABORATORY OF NUCLEAR STUDIES

Cornell University has initiated a search for a new Director of the Laboratory of Nuclear Studies (LNS), for a term of five years, renewable, beginning July 1, 2000. The successful candidate will be appointed as a tenured Professor of Physics at Cornell University. LNS includes the CESR storage ring, a particle and astrophysics theory group, and operation of the CLEO detector. It also hosts the CHESSE synchrotron radiation facility.

The search committee welcomes applications or nominations for this position. It is recommended that such applications or nominations be accompanied by curriculum vitae and other information bearing on the candidate's qualifications for the Directorship. Relevant qualifications include leadership, scientific stature, and management skills. Communications should be sent as soon as possible, preferably before May 30, 1999, and addressed to:

Professor Persis Drell, Chair  
Director Search Committee  
Newman Laboratory, Cornell University  
Ithaca, NY 14853, USA



## Cornell University

### Floyd R. Newman Laboratory of Nuclear Studies

Cornell is an equal-opportunity / affirmative-action employer



## UNIVERSITY OF GENEVA

The Department of Nuclear and Particle Physics has an opening for a

### Research Associate ("Maître-assistant")

The position is available for the participation in the Alpha Magnetic Spectrometer project in space (AMS). Candidates must have a PhD degree in physics with appropriate experience in particle physics and detectors. Responsibilities will include Si detector construction and data analysis as well as teaching duties, in French, at the University.

Candidates should not be more than 32 years of age. The position is available for a maximum period of 4 years. The closing date for applications in June 15th, 1999.

Candidates should forward a curriculum vitae and the name of two referees to:

**Prof. Maurice Bourquin**  
Département de physique nucléaire et corpusculaire  
24, quai Ernest-Ansermet, CH-1211 GENEVE 4

Additional information can be obtained by  
**E-mail from: Divic.Rapin@physics.unige.ch**



The Department of Particles and Matter seeks for its theory group a

### Theoretical Particle Physicist

with emphasis on phenomenology. The appointment will start in spring 2000 or by agreement.

The experimental program in particle physics at PSI consists on the one hand of experiments at CERN (LHC) and DESY (HERA). On the other hand, the properties of these particles as well as of pionic and muonic atoms are studied at PSI with intensive pion, muon and neutron beams.

The successful candidate must have proven accomplishments in theoretical particle physics related to the activities above. He or she is expected to do independent research in the theory group and to interact with the experimental groups at PSI. Moreover, he or she should entertain close relationships with the neighbouring universities and assume part of the administrative duties of the theory group.

For any further information please contact Dr. A. Denner (Tel. +41 56 310 36 62, e-mail Ansgar.Denner@psi.ch) or Dr. R. Rosenfelder (Tel. +41 56 310 36 63, e-mail Roland.Rosenfelder@psi.ch).

Applications containing a curriculum vitae, a list of publications and the names of three referees should be sent before May 31, 1999 to:

**PAUL SCHERRER INSTITUT, Personnel Division, ref. code 1411, CH-5232 Villigen, Switzerland.**



DESY is a physics research laboratory with 1,400 employees and more than 3,000 guest scientists from Germany and abroad. The scientific programme includes research in particle physics and synchrotron radiation.

The H1 Collaboration at DESY is seeking an experienced

## Physicist

to coordinate the upgrade of the detector and the interaction region for high luminosity operating of the ep storage ring HERA foreseen in the shutdown of the year 2000. New tracking detectors, silicon detectors and calorimeters will be introduced. Modifications to the existing setup of calorimeters and the introduction of superconducting magnets into the existing H1 experiment have to be coordinated in close collaboration with the DESY groups. Beam induced backgrounds have to be calculated and minimised.

The candidate should have a Ph.D. in physics and long standing experience with the operation of storage ring experiments especially with silicon detectors. A thorough understanding of the requirements of large experiments is indispensable. The candidate should be knowledgeable in all aspects of calculating and handling the beam induced backgrounds, in particular the synchrotron radiation. He or she should be familiar with the infrastructure at DESY.

The position is opened within a contract with the Rheinisch-westfälische Technische Hochschule Aachen and DESY. The successful candidate will be resident at DESY.

The appointment will be indefinite with a salary according to federal tariffs (BAT II a/1 b depending on experience and qualifications).

Interested applicants should send a curriculum vitae, a list of publications and the names of three referees to:

**DESY, Personalabteilung, Notkestraße 85, D-22607 Hamburg, by April 15th, 1999. Code-Name: Koop-Aachen**

Handicapped applicants will be given preference to others with the same qualifications. Women are especially encouraged to apply for this position.

## Experimental Research Associates

The Stanford Linear Accelerator Center (SLAC) is one of the world's leading laboratories supporting research in high-energy physics. The laboratory's program includes the physics of high-energy electron-positron collisions, high-luminosity storage rings, high-energy linear colliders, and particle astrophysics.

Postdoctoral Research Associate positions are currently available with opportunities to participate in the laboratory's research program, with particular emphasis on:

- Preparing for B physics with the BABAR detector at the PEP II Asymmetric B Factory, helping to tune up the BABAR Detector hardware and software for operations and to get ready for physics analysis
- Participating in a Particle Astrophysics program studying time-dependent x-ray sources with the USA, and R&D for a high-energy gamma-ray astronomy experiment in space (GLAST)

These positions are highly competitive and require a background of research in high-energy physics and a recent Ph.D. or equivalent. The term for these positions is two years and may be renewed.

Applicants should send a letter stating their physics research interests, along with a CV and three references, to: Tanya Boysen, [tkb@slac.stanford.edu](mailto:tkb@slac.stanford.edu), Research Division, M/S 80, SLAC, P.O. Box 4349, Stanford, CA 94309. Equal opportunity through affirmative action. Visit our Web site at: [www.slac.stanford.edu](http://www.slac.stanford.edu).

Stanford Linear  
Accelerator Center  
**SLAC**



## HALL C LEAD DESIGNER (Position #PR4020)

Jefferson Lab has an excellent opportunity for a Designer to lead the design effort for Hall C. Incumbent will be responsible for setting and maintaining design standards, checking all design products for adherence to good design standards, and in conjunction with the lead engineer, sharing responsibility for proper functioning of all designs. Works from sketches and verbal descriptions to develop mechanical designs of complex systems and assemblies. Sizes components using standard nomographs and formulas, and chooses components and fasteners based on expected loads and applicability for function. Responsible for supervising Hall C design staff. Plans design work, and selects parts and details from assemblies and models. Maintains the design log and the design files structure for Hall C, and oversees proper file organization and archiving.

**Minimum Qualifications:** A.A.S. Degree in Mechanical Design plus fifteen years experience or the equivalent combination in education and training. Design experience in directly applicable areas (e.g., superconducting magnets, cryogenic systems, high vacuum systems, nuclear or high-energy particle detectors, nuclear shielding, etc.) At least five years commensurate supervisory experience. CAD experience with the Hewlett Packard ME-10 and SDRC IDEAS Master Series 6 and familiarity with ANSI 14.5 required. Must have extensive direct design experience in most of the following areas: Superconducting Magnets, Cryogenic systems, High Vacuum systems, Cryogenic Nuclear Physics targets, Nuclear or High Energy particle detectors, large movable steel structures, nuclear shielding, lifting and handling fixtures and remote manipulators.

The starting salary range for the position is \$53,000 - \$83,900. For prompt consideration, please submit resume specifying position number and job title to: Jefferson Lab, ATTN: Employment Manager, 12000 Jefferson Avenue, Newport News, VA 23606.

*Proud to be an Equal Opportunity, Affirmative Action Employer.*

# MIT

## COMPUTER FACILITY MANAGER

The Laboratory for Nuclear Science seeks an individual to manage the overall delivery of both research and administrative computer services. The computer facility provides Digital UNIX and Linux operating system environments for the theoretical and experimental high energy and nuclear physics research computing programs at MIT. There is an expanding Windows/NT presence in the research areas. The lab maintains its own subnet within MIT. The Computer Group provides network connectivity for several hundred hosts and multiple protocols. This group also supports Windows NT and ORACLE for the financial and administrative groups.

**Requirements:** an advanced degree in a technical field, preferably with a background in physics. Must have a minimum of five years of relevant experience, at least two of which must be managerial experience at a complex computing facility, preferably in an education and/or research environment. Must possess excellent written, verbal, and interpersonal communication skills. Should be capable of capitalizing on new developments in the computing field to enhance the quality of computing support. Must be able to organize, budget, and manage the staff to implement and deliver these new relevant technologies to the laboratory in a timely manner. Visit our website: <http://www-lns.mit.edu>

Interested candidates should submit a resume and cover letter referencing Job No. 99-0133R to: Kenneth Hewitt, MIT Personnel, PO Box 391229, Cambridge, MA 02139-0013. To apply on-line: [web.mit.edu/personnel/www/resume.htm](http://web.mit.edu/personnel/www/resume.htm).



**MASSACHUSETTS INSTITUTE OF TECHNOLOGY**

An Equal Opportunity/Affirmative Action Employer  
Non-Smoking Environment  
[web.mit.edu/personnel/www](http://web.mit.edu/personnel/www)

**Departamento de Física Teórica, Atómica y Molecular  
Universidad de Valladolid, Spain.**

Candidates are invited for a post-doctoral position to work on the electronic structural and transport properties of carbon and composite-nanotubes with particular emphasis on theoretical calculations of interest for: STM microscopy, nanodevices, chemical activity, mechanical behaviour, optical response. Knowledge of molecular dynamics and electronic structure calculations desirable.

The position, included in an EU-funded TMR Network on Nanotubes for "Microstructure Technology" (NAMITECH) is immediately available and is for two years.

Details on how to apply and restrictions may be found at:  
<http://www.fam.cie.uva.es/~arubio>.

**PhD Programs**

Ohio University, Department of Physics and Astronomy,  
Athens - USA

The Department of Physics and Astronomy at Ohio University currently has openings for graduate students in the MS and PhD programs. Areas of specialization are nuclear and particle physics, solid state and surface physics, astrophysics, nonlinear dynamics, chaos, and applications to neuroscience. The department awards Graduate Teaching and Research Assistantships with annual stipends ranging from \$14,000 to \$14,900 plus tuition.

Further information can be found at

<http://www.phy.ohiou.edu/programs.html> or obtained from the Department of Physics and Astronomy, Ohio University, Athens, OH 45701, USA. E-mail: [elster@ohiou.edu](mailto:elster@ohiou.edu)

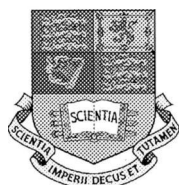

**Imperial College of  
Science, Technology  
and Medicine London**

**Lectureship in High Energy Physics**

Applications are invited for the post of Lecturer in High Energy Physics at the Blackett Laboratory, Imperial College, London.

The group's active experimental programme embraces the ALEPH experiment at LEP, the ZEUS experiment at HERA, the BABAR experiment at SLAC, the CMS and LHC-B experiments at LHC and the UK Dark Matter Experiment. It has also recently joined the D0 experiment at the Tevatron. Within the group there is a strong tradition of detector development and construction which has led to key activities in the above experiments. Further details of the group's programme may be found on:

<http://www.hep.ph.ic.ac.uk/>

It is anticipated that the starting date for this position will be October 1st, 1999 and that the appointee will initially take responsibility for the new D0 activity.

Following a successful 3 year probationary period this will become a tenured teaching position.

Salary will be in the range £16,655 - £29,048 plus £2,134 London allowance.

**Further information may be obtained from**

Professor P J Dornan,  
Blackett Laboratory, Imperial College, London SW7 2AZ, UK.  
Email: [PDornan@ic.ac.uk](mailto:PDornan@ic.ac.uk)

to whom applications, comprising a curriculum vitae, a list of publications and the names and addresses of three referees should be sent, by **10 May 1999**.

*The College is striving towards Equal Opportunities  
At the leading edge of research, innovation and learning*

Visit our Website

[WWW.KNOWLEDGEFOUNDATION.COM](http://WWW.KNOWLEDGEFOUNDATION.COM)

Commercialization Advances in

**LARGE-SCALE PRODUCTION OF  
CARBON  
NANOTUBES**

THE LOEWS L'ENFANT PLAZA • WASHINGTON, D.C  
APRIL 22-23, 1999

**TECHNICAL ADVISORY COMMITTEE**

**Dr. Daniel T. Colbert,**  
*Department of Chemistry & Center  
for Nanoscale Science & Technology,  
Rice University*

**Dr. Ching-Hwa Chiang,**  
*Department of Chemistry,  
University of California,  
Los Angeles*

**Dr. Robert C. Haddon,**  
*Department of Organic Chemistry,  
University of Kentucky,  
& Carbon Solutions, Inc.*

**Dr. Stephen R. Wilson,**  
*Department of Chemistry,  
New York University*

This powerful conference is designed to specifically address current scientific understanding, latest data and technological advances in the production and chemical processing of carbon nanotubes. Space is limited!

**CALL TODAY FOR MORE INFORMATION:**

The Knowledge Foundation, Inc.  
101 Merrimac, Boston, MA 02114  
(617) 367-7979 phone • (617) 367-7912 fax  
e-mail: [custserv@knowledgefoundation.com](mailto:custserv@knowledgefoundation.com)

**OTHER KNOWLEDGE FOUNDATION EVENTS**

Materials Discovery, Synthesis and Optimization for the Commercialization of both

**Small Molecule & Polymer Light Emitting Devices**

April 26-27, 1999 • San Diego, CA

Commercialization of

**Fuel Cells for Portable Applications**

April 29-30, 1999 • Washington, DC

**Materials Informatics**

June, 1999

Managing materials discovery & development data  
Integration of physics, chemistry & engineering data

VISIT OUR WEBSITE OR CONTACT US FOR MORE INFORMATION

1380AD



ORGANIZED AND SPONSORED BY:

**THE  
KNOWLEDGE FOUNDATION  
INC**



# European Sales Manager

Initially for Maternity Cover - April to August '99.

**Location Flexible:** Paris, Bristol or Home

**We are:** An international publisher of scientific journals, books, reference works and magazines, and a world leader in electronic publishing.

**We are looking** for an experienced salesperson to cover Scandinavia, Germany, Paris & Eastern France, Switzerland, & Eastern Europe and to sell our journals, consortia deals, bibliographic database and books in those countries.

**You will** be an experienced publishing salesperson with at least fluent German and everyday French and will have some knowledge and experience of STM market conditions. Negotiation skills and basic contractual legal knowledge will be most useful. You must be prepared to be on the road for 3 weeks out of every 4 and need to be comfortable with on- and offline computer presentations to individuals and groups.

A results orientated self-starter is required as much of the work is unsupervised.

Benefits include salary in the region of £23,000, generous travel and accommodation allowances, paid sick leave, private medical scheme and attractive non-smoking offices in either Paris or Bristol. Alternatively the job holder may work from home. Initially this post is to cover maternity leave, however it could be extended to a full or part-time, permanent position.

To apply, please send your CV and current salary details to:

Margaret Williams, Institute of Physics Publishing  
Dirac House, Temple Back  
Bristol BS1 6BE

For more details about IOPP  
see <http://www.iop.org>



**Institute of Physics** PUBLISHING

INVESTOR IN PEOPLE

# DISCUSSION MEETING

**THE ROYAL SOCIETY**

## Magnetic Activity In Stars, Discs And Quasars

Discussion Meeting on 19-20 May 1999 (all day)  
Organisers: Professor D Lynden-Bell, Professor ER Priest and Professor NO Weiss  
*Greatly improved data are giving new stimulus to magnetic theories of the heating of the coronae of stars, to the understanding of angular momentum transport in accretion discs, and to theories of the collimation of the jets from them. Such jets long known in radio-galaxies and quasars are now seen around young stars and in the superluminal micro-quasars within the Galaxy. X-ray bursts may themselves be related to the jet phenomenon.*

## Geomagnetic Polarity Reversals And Long Term Secular Variation

Discussion Meeting on 7-8 July 1999 (all day)  
Organisers: Professor D Gubbins, Professor D Kent and Professor C Lai  
*The Earth's magnetic field changes in response to fluid flow in the liquid iron core, leaving a record in magnetised rocks. This meeting will bring together theoreticians developing increasingly sophisticated computer models of the Earth's dynamo with experimentalists making detailed analyses of the magnetic record.*

There is no charge for registration for Discussion Meetings  
Further details can be obtained from: Science Promotion Section,  
The Royal Society, 6 Carlton House Terrace, London, SW1Y 5AG  
Tel: 0171 451 2574/2575; Dept Fax: 0171 451 2693  
Email: [discussion.meetings@royalsoc.ac.uk](mailto:discussion.meetings@royalsoc.ac.uk); WWW: <http://www.royalsoc.ac.uk>  
The Royal Society is a registered charity

promoting excellence in science

# INDEX TO ADVERTISERS

## DISPLAY

Advent Research Materials	42	Hamamatsu Photonics (KK)	OBC
Aventis	24	High Voltage Technology	42
Bergoz	8	Hitec Power Protection	17
Bertan High Voltage	4 & 42	Institute of Physics Publishing	21
BICRON	16	Janis Research	42
Caburn mdc	IBC	Lake Shore Cryotronics Inc	28
Cambridge University Press	40	Maehlum Instruments AS	17
Ceramaseal	42	Metrolab 2	0
Ceramic Seals	42	NAG	10
Communaute de Communes du Pays de Gex	28	PhiTec AG	17
Creative Electronics Systems AG	6	Testbourne	42
Diversified Technologies	IFC	Thevenet & Clerjounie	28
Europa metalli	8	Vacuum Solutions	12
Goodfellow Cambridge	42	VAT Vacuum Products	8
		Weka AG	21

# Recollections of Edoardo Amaldi

*20th Century Physics: Essays and Recollections, a Selection of Historical Writings by Edoardo Amaldi*, World Scientific 9810223692 (£83).

This interesting book was published in the Edoardo Amaldi Foundation Series and, as Ugo Amaldi, Edoardo's son, writes in the preface, "offers, by reading Amaldi's own words, the occasion to delve into his way of viewing the people he liked and the events which he had participated in".

It contains a collection of articles and speeches by Amaldi and gives sometimes very personal views, being based "in part on my memory and personal diary". Although intended to be a historical book, it cannot conceal Amaldi's deep love of science. Hence even the recollections of old friends are full of interesting scientific anecdotes.

The text contains two parts: "From nuclei to particles: 50 years of physics in Italy"; and "European physicists and their institutions". I found the articles describing the work of Fermi's group at Rome from 1934 to 1936 particularly fascinating. Amaldi describes from his own experience the exciting developments of the time, with details of the experimental arrangements and, for example, the correspondence with Rutherford.

As well as the rise of the Rome group, he relates the creation of the group at Florence, which was engaged mainly in cosmic ray physics. After the years of glory, Amaldi, in his typical sober and objective style, also covers the dark times of decay, of racial persecution and of emigration of many Italian physicists. It is touching to read the reasons for Amaldi's decision not to join the emigration, although in 1942 he was onboard a ship sailing for the USA.

Several articles deal with the resurrection of Italian physics after the war, starting from the beginnings after the arrival of Allied troops in Rome, when cosmic-ray equipment built by Conversi and Piccioni was recommissioned, and the gradual build-up of new groups, under the leadership of Bernardini and Ferretti

among others, which eventually led to a flourishing new physics in Italy and also included groups in fields like optics and solid-state physics.

Knowing Edoardo, I am not surprised that his own contributions are played down. Of course, many articles are devoted to the foundation of CERN in which Amaldi as first secretary-general played such an important role. His recollections provide an extremely interesting complement to the description of CERN's foundation, written by professional historians. They include inside stories about divergences involving P Auger (director at UNESCO), I Rabi, N Bohr and H A Kramers (president of IUPAP), and they relate how the final agreement to create a particle physics institute at Geneva was reached, pushed by the strong desire of the European physicists to be able to compete on a worldwide scale.

Regrettably, Amaldi mentions only briefly the time before UNESCO came into play, probably because he was then less involved. However, in this key phase of the history of CERN, the wish of the physicists was preceded by far-sighted politicians advocating a united Europe. Denis de Rougemont (who considered himself to be one of the founding fathers of CERN but is only mentioned once by Amaldi) told me about this crucial 1949 political initiative when I explained to him the LEP project.

To my knowledge, CERN is the only laboratory created to foster science and international collaboration. The great human qualities of Amaldi are revealed when he writes about his friends. His closest colleagues were G C Wick, B Touscheck and F G Houtermans. Amaldi gives a full account of their scientific achievements, but also offers warm words about the personal relations, and reports many interesting and amusing stories (among them 11 pages of cartoons drawn by Touscheck) about their careers.

Many reminiscences concern the then famous groups at Leipzig with W Heisenberg



*Edoardo Amaldi – human qualities.*

and at Copenhagen with N Bohr. Another long chapter is devoted to the genius of E Majorana, describing his conversion from an engineer to a theoretical physicist, his ability to make complicated computations in his head, and his remarkable life, including his mysterious disappearance.

A reprint of the CERN John Adams Lecture summarizes the brilliant career of Adams not only at CERN, but also in plasma physics, and demonstrates again Amaldi's deep attachment to the laboratory that he helped to create.

Finally, several articles deal with the scientific work and personal careers of friends who have contributed to the development of Italian physics, including E Persico, E Pancini and G Placzek.

The editors did an excellent job in preparing this book. All of the articles, including those originally written in Italian, appear in English. For some of them it is not clear where they were originally published or presented. I also regret the omission of a good photograph of Edoardo. However, this also reflects his modesty. The book captures the personality of a remarkable man, a great scientist and a perfect human character whom I had the honour and pleasure to know.

*Herwig Schopper / Director-General of CERN, 1981–88*

## More books

● *Information and Biographical Guide* by M G Shafranov (in Russian) Joint Institute for Nuclear Research, JINR Press 5 85165 488 0 (US\$ 15). Produced and published by the Joint Institute for Nuclear Research (JINR), Dubna, near Moscow, this is a compilation of JINR discoveries, prizes and literature, and of its scientists, history and much other useful information. The book includes more than 500 short biographical summaries of the scientists who created this research centre, who have worked or are working there, including specialists in physics, mathematics, chemistry, radiobiology and engineering from more than 20 countries. E-mail "post@office.jinr.ru", fax (7 095) 975 23 81.

● *Applications of Noncovariant Gauges in the Algebraic Renormalization Procedure* by A Borech, S Emery, O Moritsch, M Schweda, T Sommer and H Zerrouki, World Scientific 9810234562. This text goes a step beyond the algebraic formulation of renormalization using covariant gauges.

● *Sources and Detection of Dark Matter in the Universe* edited by D B Cline, Proceedings of the Workshop on Primordial Black Holes and Hawking Radiation and 3rd International Symposium on Sources and Detection of Dark Matter in the Universe, 17–20 February 1998, Marina del Rey, reprinted from *Physics Reports*, Elsevier Science.

● *Hadrons in Dense Matter and Hadrosynthesis* edited by Jean Cleymans, Hendrik B Geyer and Frederik G Scholtz, Proceedings of the 11th Chris Engelbrecht Summer School, Cape Town, 4–13 February 1998, Springer 3 540 65209 4.

● *Lectures in Synergetics* by Volodymyr I Sugakov, World Scientific 9810234953 (hbk £28).

In the World Scientific series on Nonlinear Science

● *Introduction to Quantum Computation and Information* edited by Hoi-Kwong Lo, Sandu Popescu and Tim Spiller, World Scientific 981023399X (hbk £35).

This provides an introduction to a dynamic new subject. The book is partially based on lectures organized by the editors and given at the Basic Institute in the Mathematical Sciences, Hewlett-Packard Laboratories, Bristol, UK.

## Max Born prize

The UK Institute of Physics and the German Physical Society have awarded the Max Born medal and prize for 1999 to John Dainton of Liverpool for outstanding contributions to physics, in particular his pivotal role in a series of experiments at the DESY laboratory in Hamburg, which have provided new insights into the structure of the photon and proton.

As a research student at Oxford, Dainton used hadronic beams and bubble chambers, but all of his subsequent research has been carried out using counter experiments with beams of real photons, electrons and positrons, and electrons and protons. He believes strongly that an experimentalist should be able to contribute to detector construction and physics analysis.

From his work in the early 1980s with the PLUTO collaboration at the PETRA electron-positron collider at DESY, Dainton produced valuable measurements of real photon structure. This remained a vital benchmark until recently, when his group at Liverpool extended the kinematical range. He led the UK group in the design and construction of the H1 detector at DESY's HERA electron-proton collider and carried out the first H1 measurements, which revealed new behaviour similar to hadronic diffraction. He was appointed H1 physics coordinator in

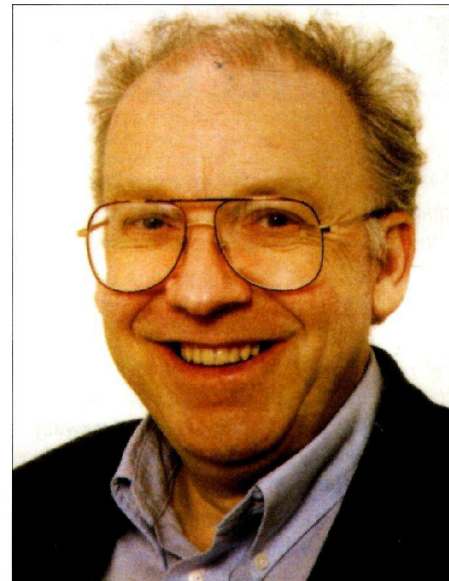

John Dainton – Max Born Prize.

1995 and played a major role in the analysis of intriguing wide-angle scattering events.

The German Physical Society (Deutsche Physikalische Gesellschaft) and the UK Institute of Physics award the Max Born prize annually in memory of the work of Max Born (1882–1970) in Germany and the UK. First awarded in 1973, the prize goes to British and German physicists in alternate years.

## Bogoliubov prize for young scientists

The Joint Institute for Nuclear Research, Dubna, near Moscow, has set up the N N Bogoliubov prize for Young Scientists in memory of the eminent physicist and mathematician Nikolai Nikolaevich Bogoliubov (1909–92).

The prize will be awarded to young (up to 33-year-old) researchers for outstanding contributions in fields of theoretical physics related to Bogoliubov's scientific interests. As a rule the prize will be awarded to a scientist who has shown early scientific maturity and whose results are recognized worldwide. Entries should try to emulate Bogoliubov's own skill in using sophisticated mathematics to attack concrete physical problems. The first prize will be awarded this summer and presented at the conference marking the 90th

anniversary of Bogoliubov's birth, which is to be held in Dubna at the end of September.

Entries (including a curriculum vitae and a one- or two-page abstract of the submitted papers) should be forwarded to the Directorate of the Bogoliubov Laboratory of Theoretical Physics of the Joint Institute for Nuclear Research by 1 May (e-mail "premia99@thsun1.jinr.ru") or to Dr V I Zhuravlev, Scientific Secretary of Bogoliubov Laboratory of Theoretical Physics, JINR, Joliot-Curie str. 6, 141980 Dubna, Russia.

● Nikolai Nikolaevich Bogoliubov's scientific activity began in Kiev at the age of 14 and important results followed from the age of 20. His main interests were nonlinear mechanics, statistical physics, quantum field theory and elementary particle theory.

## Matsuo Science award



Celebrating the Matsuo Science award in Tokyo. Norio Morita (second from left) is congratulated by Toshimitsu Yamazaki (right); looking on are E. Widmann (Tokyo University, left) and J.Eades (CERN, second from right).

Norio Morita of the Institute for Molecular Science, Okazaki, Japan, has received the Matsuo Science Award for his contribution to the laser spectroscopy of antiprotonic helium atoms. Prof. Morita was a familiar figure at the CERN LEAR experimental hall between 1993 and 1996, where these experiments were carried out by the PS205 collaboration. He

will soon return to the AD hall to continue these experiments as a member of the ASACUSA collaboration. The Matsuo Foundation in Japan has now made the unusual step of awarding annual prizes for both scientific research and for musical performance and composition. Norio Morita is the second recipient of the Science award.



**Masatoshi Koshiba**, Professor Emeritus of the University of Tokyo and founder of the Kamiokande and SuperKamiokande underground experiments, received the *Diplom di Perfezionamento honoris causa* of Pisa's Scuola Normale Superiore on 15 January.

## Kenneth A Johnson 1931–99

Kenneth A Johnson of MIT, who was a world authority on quantum electrodynamics and quantum field theory, died on 9 February.

After studying at the Illinois Institute of Technology and Harvard University, he became research fellow and lecturer at Harvard and a National Science Foundation fellow at the Institute for Theoretical Physics in Copenhagen, Denmark, before joining the MIT faculty in the autumn of 1958 and becoming a full professor in 1965.

His research deepened our understanding of quantum field theory and quantum electrodynamics. In quantum field theory he was the first to observe the dimensional and chiral anomalies. His work in quantum chromodynamics provided a method of describing the properties of a system of confined quarks – the famous MIT “bag model”. He was a fellow of the American Physical Society, the American Academy of Arts and Sciences and the American Association for the Advancement of Science.

## Meetings

The 1999 LNF Spring School in Nuclear and Subnuclear Physics will take place at INFN National Laboratories, Frascati, Italy, on 12–17 April. The school is aimed at graduate students, and postgraduate and postdoctoral fellows, and it will deal with problems of current interest in elementary particle physics and connected to the activities of the INFN laboratories.

It will cover neutrino masses and oscillations, with a visit to the Gran Sasso Laboratories; “The Hunting of the Higgs” and seminars on searches at LEP and hadron colliders; CP-violation in the K- and B-system; progress of the DAPHNE electron-positron accelerator and on the status of the experiments KLOE, DEAR and FINUDA; and reports from the working groups of EURO DAPHNE, the theoretical network studying DAPHNE physics.

The updated and complete programme of events can be found at “<http://www.lnf.infn.it/lnfss99>”.

# The latest in particle physics – from Cambridge

## String Theory

Volume 1: *An Introduction to the Bosonic String*

Volume 2: *Superstring Theory and Beyond*

Joseph Polchinski

The two volumes that make up *String Theory* provide an up-to-date, comprehensive and pedagogic introduction to the subject. Volume 1 gives a thorough introduction to the bosonic string, based on the Polyakov path integral and conformal field theory. Volume 2 begins with an introduction to supersymmetric string theories and goes on to a broad presentation of the important advances of recent years. Many exercises are included. These volumes provide an essential text for graduate students and researchers.

### Volume 1

£32.50 HB 0 521 63303 6 422pp 1998

### Volume 2

£35.00 HB 0 521 63304 4 552pp

### Two-Volume set

£65.00 HB 0 521 63312 5 552pp

*Cambridge Monographs on Mathematical Physics*

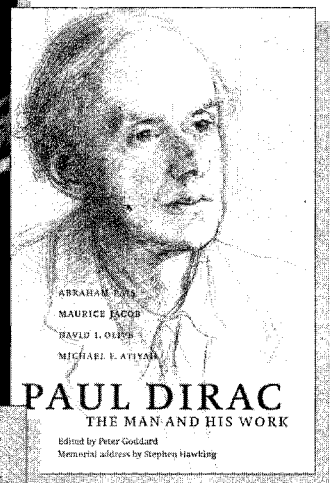
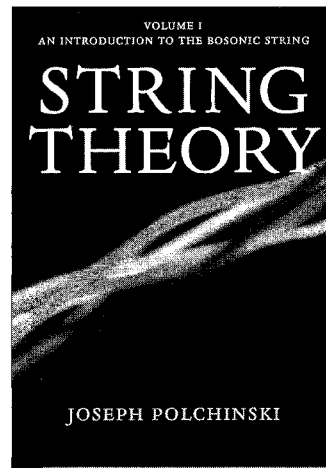

## Detectors for Particle Radiation

Second edition

Konrad Kleinknecht

This textbook provides a clear, concise and comprehensive review of detectors of high-energy particles and radiation. This second edition has been thoroughly revised and updated to include all the latest developments in detector technology.

£52.50 HB 0 521 64032 6 246pp 1998

£19.95 PB 0 521 64854 8

New  
Edition  
Textbook

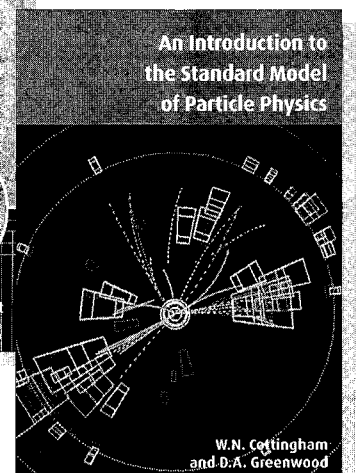
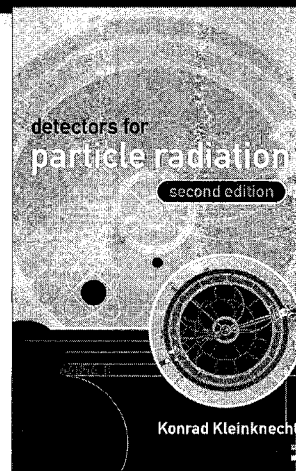

## An Introduction to the Standard Model of Particle Physics

W. Noel Cottingham and Derek A. Greenwood

This introductory graduate textbook provides a concise but accessible introduction to the current understanding of particle physics. Only an undergraduate background in mathematics is assumed, and each chapter is rounded off with a set of problems and outline solutions.

£47.50 HB 0 521 58191 5 253pp 1998

£17.95 PB 0 521 58832 4

## Paul Dirac

*The Man and his Work*

Abraham Pais, Maurice Jacob, David I. Olive and Michael F. Atiyah

Provides a unique insight into Dirac's character and his scientific achievements.

'Paul Dirac is an enigma. Unquestionably the greatest British theoretical physicist of this century ... This is a beautiful little book, a pleasure to read an excellent memorial to a truly extraordinary physicist.' *European Journal of Physics*

£13.95 HB 0 521 58382 9 140pp 1998

## Particle Physics and the Schrödinger Equation

Harald Grosse and André Martin

Introduces modern developments on the bound state problem in Schrödinger potential theory and its applications in particle physics. Covers two-body problems, relativistic generalisations, the inverse problem, 3-body and N-body problems. Emphasis is given to showing how theory can be tested by experiment. Many references are provided.

£37.50 HB 0 521 39225 X 179pp 1997

*Cambridge Monographs on Particle Physics, Nuclear Physics and Cosmology, 6*

## The Rise of the Standard Model

*A History of Particle Physics from 1964 to 1979*

Lillian Hoddeson, Laurie M. Brown, Michael Riordan and Max Dresden

'... a beautifully produced collection of essays by most of the leading scientists involved - including no fewer than eight Nobel laureates - and several eminent historians.' *New Scientist*

£55.00 HB 0 521 57082 4 744pp 1997

£24.95 PB 0 521 57816 7

## The Lund Model

Bo Andersson

Covers theory and experiment in the dynamics of the massless relativistic string, confinement, causality and relativistic covariance, Lund fragmentation processes, QED and QCD Bremsstrahlung, multiplicities and particle-parton distributions.

£80.00 HB 0 521 42094 6 484pp 1998

*Cambridge Monographs on Particle Physics, Nuclear Physics and Cosmology, 7*

Cambridge books are available from good bookshops - alternatively phone UK +44 (0)1223 325588 to order direct using your credit card, or fax UK +44 (0)1223 325152. For further information, please email [Giulia.Williams@science@cup.cam.ac.uk](mailto:Giulia.Williams@science@cup.cam.ac.uk) or browse our Worldwide Web server <http://www.cup.cam.ac.uk>

 **CAMBRIDGE**  
UNIVERSITY PRESS

The Edinburgh Building  
Cambridge, CB2 2RU, UK  
<http://www.cup.cam.ac.uk>



## Henry Kendall 1926–99

MIT professor Henry W Kendall, a 1990 Nobel Laureate and long-time environmentalist, died while diving in February. He was 72 years old.

Along with Jerome Friedman and Richard Taylor, he was one of the key members of the team studying the scattering of high-energy electron beams at the then new two-mile linear accelerator at SLAC, the Stanford Linear Accelerator Center, which in 1967 found the first experimental evidence for hard scattering centres deep inside the proton. These centres were to be identified as quarks. Prof. Kendall studied mathematics at Amherst College, graduating in 1950, and earned a physics PhD at MIT in 1955. He taught at Stanford from 1956 to 1961, before joining the MIT faculty in 1961 then becoming a full professor in 1967 and the J A Stratton professor of physics in 1991.

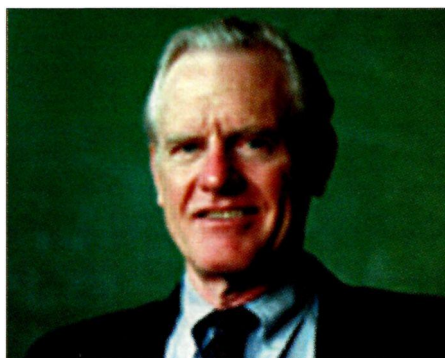

Henry Kendall 1926–99.

A founding member of the Union of Concerned Scientists in 1969, Prof. Kendall served as its chair for the past 25 years. He was deeply involved with arms control and nuclear power safety issues. He played a leading role in organizing scientific community statements on global problems, including the Call for Action at the Kyoto Climate Summit in 1997 and the World Scientists' Warning to Humanity in 1992. He was on a panel of scientists who briefed President Clinton on the

dangers of global warming in 1997. For 10 years Prof. Kendall advised the Department of Defense as a member of the Jason Group and the Institute for Defense Analysis.

In addition to the Nobel Prize, he received the Bertram Russell Society award in 1982, the Environmental Leadership award from Tufts University's Lincoln Filene Center in 1991, the Ettore Majorana-Erice Science for Peace prize in 1994, the Award for Leadership in Environmental Stewardship from the Johns Hopkins Center for a Livable Future in 1997 and the Nicholson Medal for Humanitarian Service from the American Physical Society in 1998.

In addition to his intellectual accomplishments, he was an accomplished mountain climber, scuba diver and photographer. During his college years he co-authored successful books on shallow water diving and on underwater photography. Later efforts included *Energy Strategies: Toward a Solar Future* in 1980, *Beyond the Freeze* in 1982, *Fallacy of Star Wars* in 1985 and *Crisis Stability and Nuclear War* in 1988.

## Bjoern Wiik 1937–99

Bjoern Wiik, one of the most dynamic figures on the world particle physics scene and the chairman of the directorate of the DESY Laboratory in Hamburg died in a domestic accident on 26 February.

Born in Norway, Wiik moved to Germany in 1956 for nine years of physics studies. From 1965 he spent seven years at SLAC, Stanford, where his lifelong interest in high-energy physics was kindled.

In 1972 he came to DESY, becoming Leading Scientist in 1976, and a key member of the TASSO detector team at the PETRA electron-positron collider, which went on to discover gluon effects in 1979. He shared the European Physical Society's 1995 High Energy and Particle Physics prize for this work.

During this time, Wiik also pushed forward the idea of what was later to become the 6.4 km circumference HERA electron-proton collider at DESY. In the early 1970s, several world projects included an electron-proton collision option.

Many of these fell by the wayside, but a 1977 paper by Wiik and Chris Llewellyn Smith

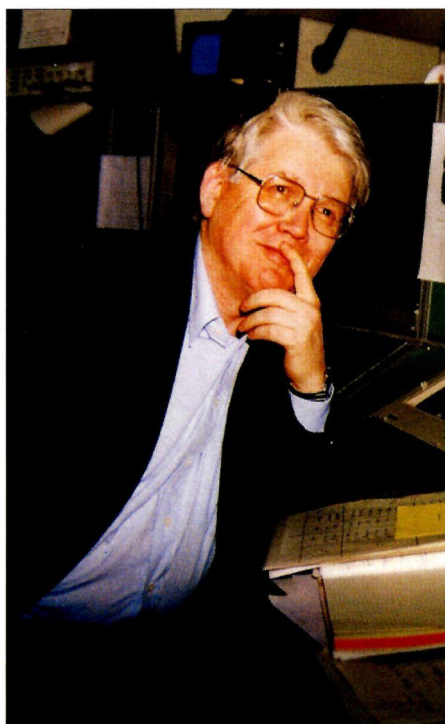

DESY director Bjoern Wiik, a physicist who was equally at home in an accelerator control room.

underlined the important physics potential of using electrons as a probe of hadron struc-

ture. HERA was pushed strongly by the physics community from 1980, finally becoming operational in 1992 and providing an important new focus for world particle physics research in Europe. Wiik led the work for HERA's high-technology superconducting proton ring. The new physics insights that HERA has produced testify to Wiik's imagination and insight into pushing such an unusual physics scenario.

In 1993 Wiik became chairman of the DESY directorate, succeeding Volker Soergel. As well as nurturing the HERA experimental programme at DESY, he was extremely proud of DESY's growing multidisciplinary role as a synchrotron radiation centre and of the integration into DESY of the former East German particle physics centre at Zeuthen, near Berlin.

Wiik saw DESY continuing as one of the few national labs to figure also a major world accelerator centre, and he was a key player in the world effort for a new generation of electron-positron colliders, with an international 33 km superconducting TESLA machine and associated developments envisaged for DESY.

Most recently he was also chairman of the International Committee for Future Accelerators, and he had characteristically channelled much energy into this influential role.

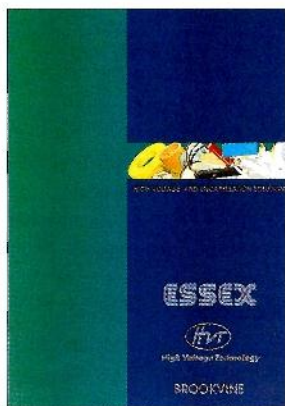

## High Voltage Technology

### High Voltage Components

The latest brochure from High Voltage Technology provides an overview of a unique resource available to the scientific community. High Voltage interconnects and Special Cast Epoxy Assemblies are covered, as well as a description of HVT's overall capability.

Tel. +44 1371 87566  
 Fax +44 1371 875665  
 E-mail [djw@hvtdemon.com.uk](mailto:djw@hvtdemon.com.uk)



## Goodfellow

### Metals and Materials in small quantities for R&D and prototype development

70 Pure Metals, 200 Alloys, 57 Ceramics as well as many Composites and Compounds in 28 forms including foil, rod, tube, wire, powder, etc. The new product guide is now available, detailing standard ex-stock and custom-made items.

Goodfellow Cambridge Ltd, Cambridge Science Park, Cambridge CB4 4DJ, England  
 Freephone 0800 731 4653  
 Tel. +44 (0)1223 568068  
 Fax +44 (0)1223 420639  
 E-mail [info@goodfellow.com](mailto:info@goodfellow.com)  
 Internet <http://www.goodfellow.com>

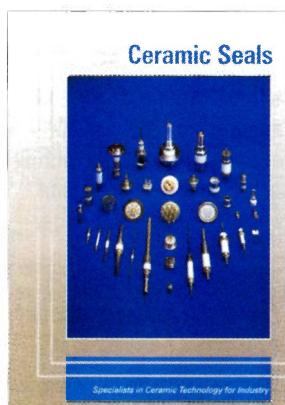

## 1999 CATALOGUE

Ceramic Seals Ltd's 1999 catalogue shows our standard range of hermetic metal to ceramic sealed assemblies and includes an extensive range of feedthroughs, vacuum hardware and sapphire viewports. In addition to this we offer design support for "specials" backed by experience with a wide range of ceramics and metal alloys.

Ceramic Seals Ltd  
 Westwood Industrial Estate  
 Arkwright Street  
 Oldham OL9 9LZ, UK  
 Tel. +44 (0)161 627 2353  
 Fax +44 (0)161 627 2356  
 E-mail [sales@ceramicseals.co.uk](mailto:sales@ceramicseals.co.uk)

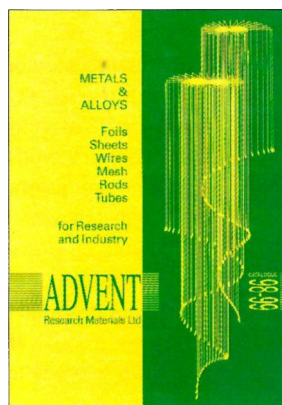

## Advent Research Materials

### Metals and Alloys for Industry and R&D

30 Metals and Alloys, 650 stock lines, 3500 standard packs. Foil, Sheet, Wire, Insulated Wire, Mesh, Rod, Tube. Small quantities, fast shipment and **very competitive prices**. Visit our Web site for more information. If what you need is not listed in our free 98-99 Catalogue, please ask for a "special order" quotation.

### Advent Research Materials Ltd

Oakfield Industrial Estate  
 Eynsham, Oxfordshire OX8 1JA, England  
 Tel. +44 (0)1865 884 440  
 Fax +44 (0)1865 884 460  
 E-mail [info@advent-rm.com](mailto:info@advent-rm.com)  
 Internet [www.advent-rm.com](http://www.advent-rm.com)



## Janis Research Co Inc

Janis proudly introduces its new line of cryostats for microscopy, imaging and inspection applications. Using our reliable and efficient SuperTran technology, these cryostats feature low inherent vibration, large optical apertures and sample mounting suited to short working length optics.

Standard and custom systems are available for a variety of applications.

Janis Research Co Inc  
 Tel. (978) 657 8750  
 Fax (978) 658 0349  
 Internet [www.janis.com](http://www.janis.com)



## 1999 BERTAN HIGH VOLTAGE POWER SUPPLY CATALOGUE

A newly updated version of Bertan's high-voltage power supply reference guide and catalogue is now available. This guide features detailed specifications on precision DC power supplies with outputs ranging from 500 V to 125 kV. The publication also includes a section covering theory of operation, a glossary of terms and a handy selection and application guide.

Bertan High Voltage Corp  
 121 New South Road, Hicksville NY 11801 USA  
 E-mail [info@bertan.com](mailto:info@bertan.com)  
 Internet <http://www.bertan.com>  
 Tel. 001 800 966 2776 or 001 516 433 3110  
 Fax 001 516 935 1766

UK sole agent: Kingshill Electronic Products Ltd  
 Tel. +44 (0)1634 821200

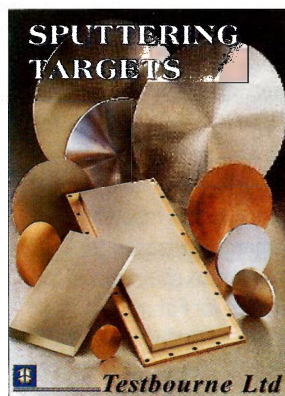

## Testbourne for thin films

The leading and most comprehensive range of quality-assured high-purity sputtering targets and backing plates, supported with a target bonding service. Alloys or compounds can be synthesized to customer specifications and confidential agreements for security of customers' R&D and production processes are offered.

Testbourne Ltd, Unit 12, Hassocks Wood Estate, Stroudley Road, Basingstoke, Hampshire RG24 8UQ, UK  
 Tel. +44 (0)1256 467055  
 Fax +44 (0)1256 842929  
 E-mail [testbourne@compuserve.com](mailto:testbourne@compuserve.com)

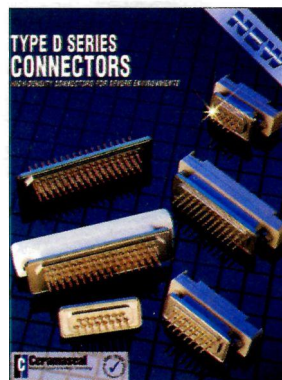

## Ceramaseal

### Type D Series Connectors

The Ceramaseal D Series connectors are designed for ultra-high vacuum (minimum leak rate of  $1 \times 10^{-9}$  standard cc He/sec, cryogenic (liquid nitrogen) and high temperatures of 350 °C. Options include 9, 15, 25 and 50-pin designs. Materials used in the connector series include 304 stainless-steel shell, gold plated pins and glass-ceramic insulation. Choice of plug materials are available depending on temperature and environmental conditions.

Call for free technical flyer  
 Ceramaseal/Meili Kryotech, Switzerland  
 Tel. +41 (0)56/245 41 45  
 Fax +41 (0)56/245 49 51  
 Headquarters USA  
 Tel. +1 518 794 7800. Fax +1 518 794 8080  
 E-mail [info@ceramaseal.com](mailto:info@ceramaseal.com)  
<http://www.ceramaseal.com>

## VACUUM SOLUTIONS FROM CABURN-MDC



Complete air-to-vacuum instrumentation connectivity

Caburn-MDC offers a complete solution to the problem of ultra-high vacuum connectivity for low voltage multipin instrumentation. Expanding on the popular Type-D subminiature connector standard, we offer a new range of UHV feedthroughs with 9, 15 or 25 pins hermetically sealed and electrically insulated using advanced glass/ceramic bonding technology.

Unlike other feedthrough products available, Caburn-MDC provides a complete connectivity solution. Complete air-side Type-D connectors are included with each feedthrough assembly. For in-vacuum connections we have developed a unique combination of in-vacuum ribbon cable and Type-D connectors which have been specially designed and constructed to meet the rigorous demands of UHV environments. All our feedthroughs are offered with a choice of KF, LF or CF flanges.

**Call us today and ask for the new Connectivity Data Sheet.**

**Caburn-MDC - The Vacuum Components Company™**

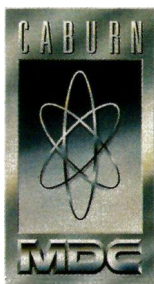

**CABURN-MDC LIMITED**

The Old Dairy, Glynde  
East Sussex BN8 6SJ  
United Kingdom  
Tel: +44 (0)1273 858585  
Fax: +44 (0)1273 858561

e-mail: [sales@caburn-mdc.co.uk](mailto:sales@caburn-mdc.co.uk)  
URL: <http://www.caburn-mdc.co.uk>

## VACUUM CONNECTIVITY

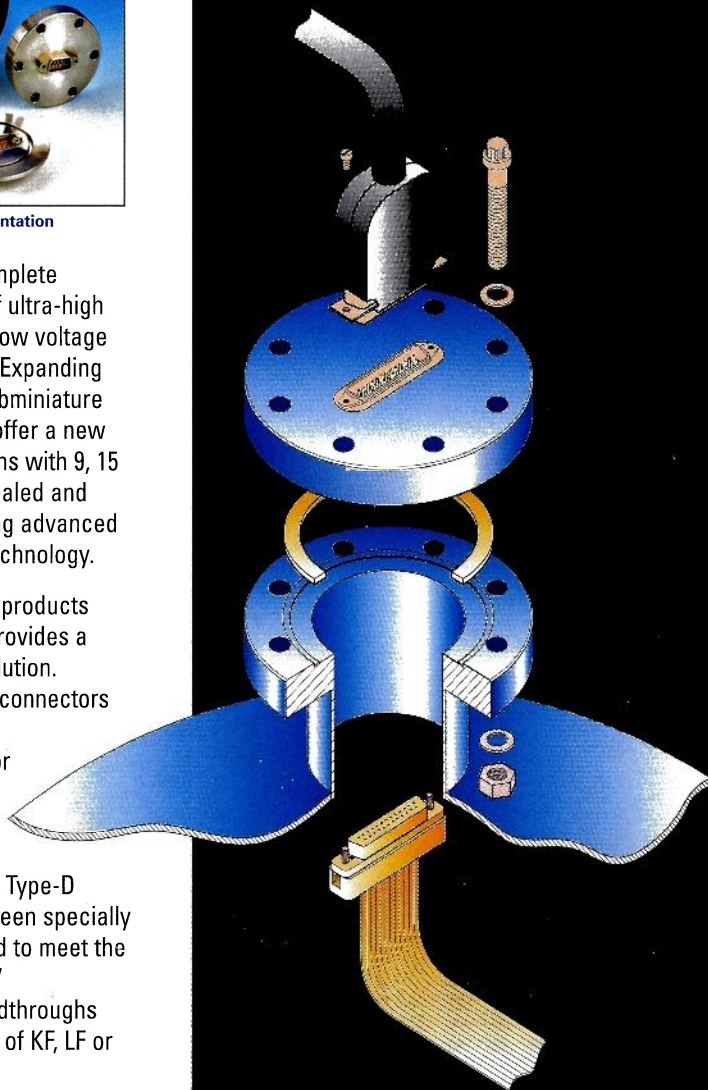

Pre-terminated Kepton® Ribbon Cable



Kepton® Ribbon Cable with PEEK In-vacuum Connector



9- & 25-Way Kepton® Ribbon Cable

- UHV Compatible
- Type-D Subminiature Air-Side Connector
- PEEK In-Vacuum Connector
- Kapton® coated UHV Ribbon Cable
- Gold Plated Pins
- CF Compatible Design



# Breakthrough PMT Innovation Getting Ready For The Year 2000!

It's almost here. The next century PMT is almost on the scene. It's a new flat-shaped, super-thin light sensor called the "Flat Panel PMT". Innovative features of this new Flat Panel PMT include multielement connections and a large sensitive area guaranteed to open the door to dramatic scientific advances in the 21st Century.



FLAT PANEL  
**PMT**



It compares with a HPK 2" diameter head-on photomultiplier tube.

HAMAMATSU PHOTONICS K.K., Electron Tube Center <http://www.hamamatsu.com>  
314-5 Shimokanzo, Toyooka-village, Iwata-gun, Shizuoka-ken, 438-0193 Japan. TEL:81-539-62-5248 FAX:81-539-62-2205

United Kingdom: Hamamatsu Photonics UK Limited. TEL:(44)181-367-3560 FAX:(44)181-367-6384  
North Europe: Hamamatsu Photonics Norden AB. TEL:(46)8-703-29-50 FAX:(46)8-750-58-95  
Italy: Hamamatsu Photonics Italia S.R.L. TEL:(39) 2-935 81 733 FAX:(39) 2-935 81 741

U.S.A.: Hamamatsu Corporation. TEL:(1)908-231-0960 FAX:(1)908-231-1218  
Germany: Hamamatsu Photonics Deutschland GmbH. TEL:(49)8152-3750 FAX:(49)8152-2658  
France: Hamamatsu Photonics France S.A.R.L. TEL:(33) 1 69 53 71 00 FAX:(33) 1 69 53 71 10  
Switzerland: CERN Liaison Office TEL:(41)31/879 13 33 FAX:(41)31/879 18 74

**HAMAMATSU**